

SHORT WAVE RADIO

June
1934



Edited by

Robert Hertzberg and Louis Martin

IN THIS ISSUE:

Foreign Station Data
for Listeners

New List of Police
Radio Stations

Byrd Antarctic Programs
Successful

Shielding at High Frequencies
By Robert S. Kruse

Filament Supplies for 2-Volt
Receivers

Five Interesting Sets for
the Constructor

The Worcester CONSTANT BAND-SPREAD SIX

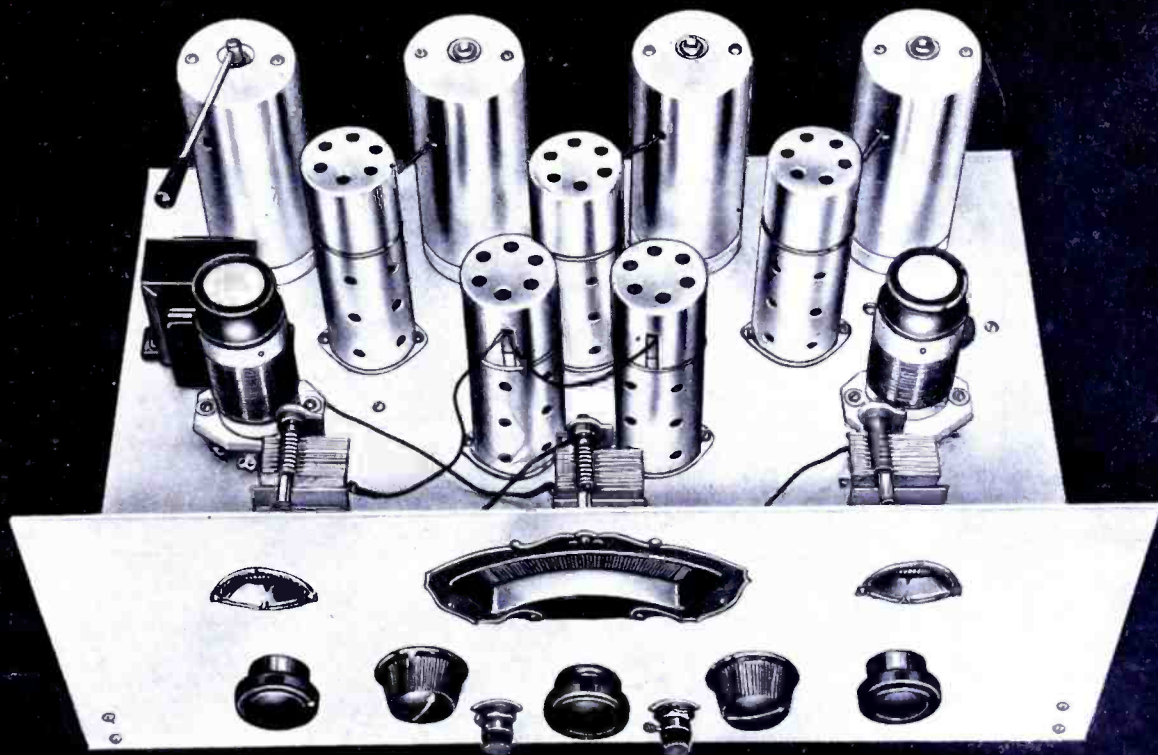

A Unique Superheterodyne
That Opens Up the Crowded
S.W. Broadcast Channels



BOOKS FOR THE RADIO MAN

Many of the questions asked daily by radio experimenters, constructors and listeners all over the country are answered completely and clearly in various books. To assist radio men in buying books best suited for their own particular needs, we have made a selection of representative works that we can recommend very highly. These books are all up-to-date and will prove very valuable.

"The Radio Amateur's Handbook"

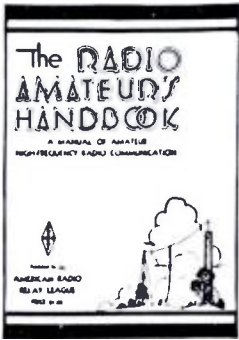

The RADIO AMATEUR'S HANDBOOK was first published in the fall of 1926. It was in response to a growing demand upon the American Radio Relay League for some sort of a manual of operation for short-wave experimental radio work. The first edition met with great favor and two reprintings were necessary to supply the demand. Since that time ten subsequent editions have been published and more than 215,000 copies have been sold. The latest edition (11th edition, published January, 1934) is approximately 15% larger than the first edition, and represents probably the most comprehensive revision yet attempted. New receiver circuits and designs are presented, together with a thorough treatment of the recently-developed "single-signal" sets. A completely re-written 36-page chapter is devoted to all that is new in the world of transmitters. New circuits and layouts are given, all problems which face the transmitting amateur being discussed in a lucid and comprehensive manner. The radio telephony chapter represents all new material. New designs for Class B modulators and speech amplifiers are featured. Still another new chapter is that on antennas. 238 pages, many illustrations.

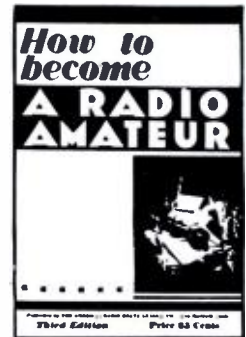

Price \$1.00 postpaid

"The Outlook for Television"

How far has television advanced? How far is it from commercial application? What form will this application take? How will it affect broadcasting, advertising, home and theatre entertainment? How will it be used in education, politics, war, and religion?

Mr. Orrin E. Dunlap, the author, tells in detail how television has been developed to date. He explains in clear, simple language the technical and scientific principles on which it rests, the obstacles which must be overcome, the probable future developments of the industry. It is a book not only of facts but of personalities. The author takes us into the television laboratories of such men as Alexander, Zworykin, Jenkins, Hammond, Baird, and others—explains the work they are doing, and presents their opinions on the future of television. The book is authoritative.

Price \$4.00
Postage extra



"How to Become a Radio Amateur"

Completely done over in 1934 style, telling all about amateur radio and describing the latest equipment—push-pull transmitter—bandspread pentode receiver—simplest of monitors.

The third edition of "How to Become a Radio Amateur" marks another milestone in amateur development. Still the standard elementary guide for the would-be amateur, the simple, inexpensive station described incorporates features which in the past have been confined to the more advanced layouts. The designs have been made flexible so that parts out of the junk box can be readily substituted. The performance of the completed station is such that any amateur can own and operate it with satisfaction and pleasure. It's a real amateur station, with construction and operation described in clear, understandable language.

Price \$.25
Postpaid

"Hints and Kinks for the Amateur"

For years hams have said that one of the most practical and valuable features of all radio magazines is the experimenter's section. But—try to recall when it was you saw that swell (but, alas, only dimly remembered) suggestion for band-spreading, or a key click eliminator. What was needed was a compilation of all the best ideas, brought under one cover, segregated by subjects, and indexed. And here it is—an intensely practical book, filled out with selected additional material, with dozens of valuable and workable ideas gleaned from the practical station experience of successful amateurs. Chapters on workshop ideas, receivers, transmitters, amateur, phone QRM elimination, keying, power supply, and so on.

An ever-present help in time of trouble, and worth its weight in crystals when you are desperate for an idea. 80 pages in attractive paper covers.

Price \$.50
Postpaid

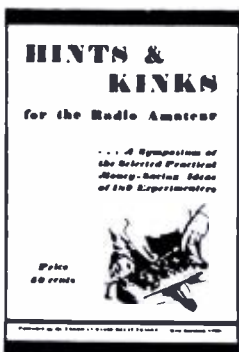

"Radio Amateur's License Manual"

Before you can operate an amateur transmitter, you must have a government license and an officially assigned call. These cost nothing—but you must be able to pass the examination. The License Manual tells how to do that—tells what you must do and how to do it. It makes a simple and comparatively easy task of what otherwise might seem a difficult task. In addition to a large amount of general information, it contains 198 typical questions and answers such as are asked in the government examinations. If you know the answers to the questions in this book, you can pass the examination without trouble.

Price \$.25. Postpaid.



The safest way to remit money is by post office or express money order. Hold your receipt until your books arrive. Do not send coins through the mail. Write or print your name and address clearly. Prompt deliveries of all orders guaranteed. No books sent on approval or C. O. D.

Standard Publications, Inc., 1123 Broadway, New York, N. Y.

How a "Tip" got Tom a Good Job



GEE, THERE'S DJ C IN BERLIN. THAT'S THE TENTH FOREIGN STATION TONIGHT. RADIO IS SURELY FUN.



HELLO, TOM, HOW'S EVERYTHING?

OH, NOT SO GOOD BILL, BUT I'M STILL HAVING FUN PLAYING WITH RADIO. HAD DJ LAST NIGHT ON A LITTLE SET I BUILT. IS RADIO STILL YOUR HOBBY TOO?



NO, TOM. I'VE BEEN TOO BUSY MAKING GOOD MONEY OUT OF RADIO TO SPEND TIME "PLAYING" WITH IT.

GOSH, BILL, YOU'RE SURE LUCKY. I NOTICED YOUR SWELL CLOTHES AND SNAPPY CAR. I THOUGHT YOU HAD INHERITED A MILLION. TELL ME ABOUT IT.

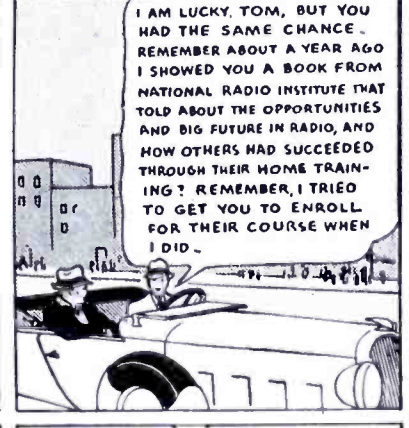

I AM LUCKY, TOM, BUT YOU HAD THE SAME CHANCE. REMEMBER ABOUT A YEAR AGO I SHOWED YOU A BOOK FROM NATIONAL RADIO INSTITUTE THAT TOLD ABOUT THE OPPORTUNITIES AND BIG FUTURE IN RADIO, AND HOW OTHERS HAD SUCCEEDED THROUGH THEIR HOME TRAINING? REMEMBER, I TRIED TO GET YOU TO ENROLL FOR THEIR COURSE WHEN I DID -



WELL, IT WAS THE SMARTEST MOVE I EVER MADE. I'M DOING SWELL. MARY AND I ARE TO BE MARRIED NEXT MONTH. TOM, WHY DON'T YOU SNAP OUT OF IT? DON'T STAY IN THAT DREARY LOW PAY JOB ALL YOUR LIFE. RADIO IS MORE THAN A PLAYTHING. IT'S A BIG BUSINESS. IT'S YOUR OPPORTUNITY. TAKE MY TIP. IT ISN'T TOO LATE. RADIO IS STILL YOUNG AND GROWING.

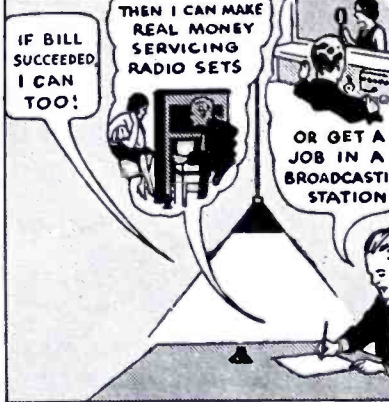

IF BILL SUCCEEDED, I CAN TOO!

THEN I CAN MAKE REAL MONEY SERVICING RADIO SETS

OR GET A JOB IN A BROADCASTING STATION

OR INSTALL AND SERVICE LOUD SPEAKER SYSTEMS

OR MAKE GOOD MONEY IN ANY ONE OF THE MANY OTHER NEW AND GROWING BRANCHES OF RADIO. THERE'S NO END OF GOOD JOBS FOR A TRAINED RADIO MAN! YES, SIR, I'M GOING TO SEND FOR THAT FREE BOOK AND GET THE DOPE RIGHT NOW!



YOU CERTAINLY KNOW RADIO. MINE NEVER SOUNDED BETTER

N. R. I. TRAINING CERTAINLY PAYS. I JUST STARTED A FEW MONTHS AGO AND I'M MAKING GOOD MONEY ALREADY. THIS SPARE TIME WORK IS SWELL FUN, AND SOON I'LL BE ALL SET FOR A GOOD FULL TIME JOB

THANKS!

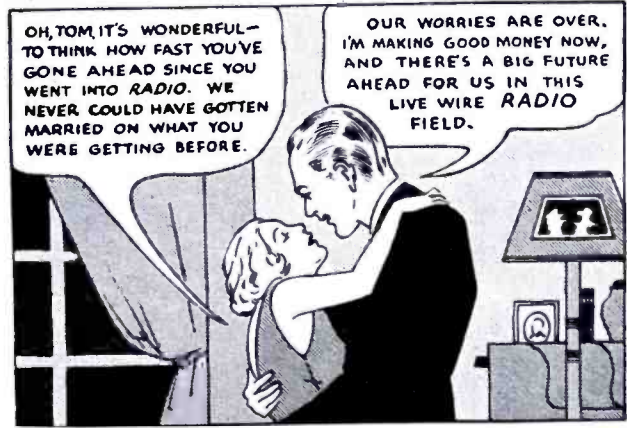

OH, TOM, IT'S WONDERFUL TO THINK HOW FAST YOU'VE GONE AHEAD SINCE YOU WENT INTO RADIO. WE NEVER COULD HAVE GOTTEN MARRIED ON WHAT YOU WERE GETTING BEFORE.

OUR WORRIES ARE OVER. I'M MAKING GOOD MONEY NOW, AND THERE'S A BIG FUTURE AHEAD FOR US IN THIS LIVE WIRE RADIO FIELD.

... I will help you start a spare time or full time Radio service business Without Capital

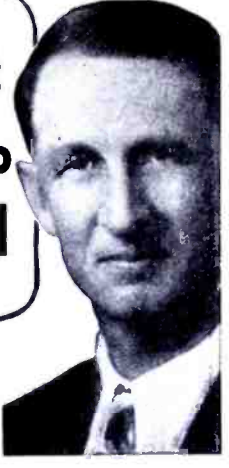

Many Radio Experts Make \$40, \$60, \$75 a Week

HERE'S PROOF THAT N.R.I. MEN MAKE GOOD MONEY

"Made \$6,000 in 2 Years"

"Soon after the depression started, I found myself without a job, but I was well protected with N. R. I. training. I swung right to full time Radio servicing and I have made over \$6,000 in a little over two years."—Wm. Spartivert, Sparty Radio Service, 93 Broadway, Newark, N. J.



"\$500 a Year in Spare Time"

"Although doing spare time Radio work only, I have averaged about \$500 a year extra in addition to my regular income. Full time Radio work would net me many times that amount."—Edw. H. Fawcett, Slough Rd., Ladner, B. C., Canada.



"Now Owns Own Business"

"If I had not taken your Course I would be digging ditches instead of running my own business. One week I made \$75 on repairing alone, and this doesn't count sales. If a fellow wants to get into radio, N. R. I. is the starting point."—R. S. Lewis, Modern Radio Service, Pittsfield, Ill.



"\$50 to \$75 a Week"

"The National Radio Institute put me in a position to make more money than I ever made in good times. I am in the Radio Service business for myself, where it is possible for me to make from \$50 to \$75 a week. Service work has increased because people, who in normal times would buy a new Radio, now are contented to have the old one 'pepped up.'"—Bernard Costa, 150 Franklin St., Brooklyn, N. Y.



The world-wide use of Radio sets has made hundreds of opportunities for good spare time or full time Radio businesses. Many of the seventeen million Radio sets are only 25% to 40% efficient. I will show you how to cash in on this condition. I will show you how to install and service all types of receiving sets in spare time. I'll show you how to make enough money while learning Radio to start your own service business. Clip the coupon below. Get my free book, "High Rewards in Radio". Read how hundreds of N. R. I. students and graduates have made good money in spare time or full time businesses.

Many Make \$5, \$10, \$15 a Week Extra in Spare Time Almost at Once

The day you enroll I send you directions for doing 28 Radio jobs common in almost every neighborhood for spare time money. I give you plans and ideas that have made \$200 to \$1,000 a year for many N. R. I. men in spare time.

Get Ready Now for Jobs Like These

In just about 15 years Radio's growth has created over 300,000 jobs. Thousands more jobs will be opened by new Radio developments. Broadcasting stations use engineers, operators, station managers and pay up to \$5,000 a year. Manufacturers employ testers, inspectors, foremen, engineers, servicemen, buyers, for jobs paying up to \$7,500 a year. Dealers and jobbers employ servicemen, salesmen, buyers, managers and pay up to \$100 a week.

Television, Short Wave, Loud Speaker Systems Included

There's opportunity for you in Radio. Its future is certain. Television, Short wave, loud speaker systems, ship Radio, police Radio, automobile Radio, aircraft Radio—in every branch, developments and improvements are taking place. Here is a real future for thousands of men who learn Radio—men with N. R. I. training. Get the training that opens the door to good pay and success.

Money Back Agreement Protects You

I am so sure N. R. I. can train you satisfactorily that I agree in writing to refund every penny of your tuition if you are not satisfied with my Lesson and Instruction Service upon completion. Get my 64-page book of facts. It's free to any ambitious fellow over 15 years of age. It tells you about Radio's opportunities; about my Course; what others are doing and making. Find out what Radio offers you. No obligation. ACT NOW! Mail coupon in an envelope, or paste it on a 1c post card.

J. E. SMITH, President
National Radio Institute, Dept. 4FS8
Washington, D. C.

out the spare time and full time job opportunities in Radio and explains your amazingly practical 80-80 method of training men quickly and inexpensively at home in their spare time to be Radio Experts.

NAME.....
ADDRESS.....
CITY.....
STATE.....

AGRE. I will send me your book which points out the spare time and full time job opportunities in Radio and explains your amazingly practical 80-80 method of training men quickly and inexpensively at home in their spare time to be Radio Experts.

MAIL THIS for FREE 64 page book

SHORT WAVE RADIO

devoted to short-wave transmission and reception in all their phases

Robert Hertzberg, *Editor*

Louis Martin, B. S., *Technical Director*

IN THIS ISSUE

Of General Interest:

Byrd Antarctic Program Successful.....	4
Unique One-Hour Program Covers World...	5
Foreign Program Notes of Interest.....	6
Best Short-Wave Stations.....	7
Station Reports from Readers.....	8
New Frequencies for Police Radio.....	10
List of International Call Assignments.....	10
Short-Wave Receiver Review.....	12
Radio Code Proves Easy for S.W. Fans.....	13
Selecting a S.W. Receiver.....	14
New Aircraft Radio Rules.....	15
A Lazy Man Listens to Europe, by Q. B. Newman	17
F. R. C. Warns on Secrecy Section of Radio Act	43

Of Explanatory Nature:

Tuning the Antenna Circuit.....	16
Does the Moon Affect Radio Reception? by Louis Martin and C. H. Lane	18
Output Transformer Chart.....	20
Filament Supplies for 2-Volt Sets.....	22
Characteristics of the 6C6 and 6D6.....	23
Shielding at High Frequencies, by Robert S. Kruse	24

For the Constructor:

Revamping the Old Super-Wasp.....	27
The Worcester Constant Band Spread Six, by J. A. Worcester, Jr.	28
The "Trophy Winner," by Frank Lester.....	32
A Coffee Can Frequency Meter for the S. W. Listener	34
The "DX-2," by Luther J. Miles.....	36
A Two-Tuned-Stage Short Wave Booster....	37

IN FUTURE ISSUES:

REVISED STATION LIST—We have already published lists of the short-wave stations of the world in various forms. We are now working on a very convenient hour-by-hour chart that will be altogether different and that will greatly simplify "fishing" for foreign stations, especially by new owners of short-wave or all-wave receivers. We have circularized practically all the stations in the world, and have been able to gather a great deal of really authentic and dependable information.

DISTORTION IN RECEPTION—The "mushy" reception often experienced on the short waves is not always due to fading of the signal itself or to variations in the medium of the path over which the signals travel. It very often is due to little-suspected faults in the receiver. These faults are more noticeable on weak signals than on strong ones. An article written in popular vein will explain the possible causes of such trouble and will tell how to remedy them.

PORTABLE RECEIVERS—With Summer on the way, many constructors are thinking of portable receivers that they can carry in their cars on week-end trips. We are putting a number of such receivers through some strenuous road tests and will describe them in detail as soon as we are satisfied with them in every respect.

The entire contents of SHORT WAVE RADIO are copyrighted by Standard Publications, Inc., and must not be reproduced without permission of the copyright owners.

SHORT WAVE RADIO—Monthly. Entered as second-class matter September 15, 1933, at the post office at Chicago, Illinois, under the Act of March 3, 1879.

SHORT WAVE RADIO is published on the first of every month preceding date of issue. Subscription price is \$2.50 a year in the United States and possessions; Canada and foreign countries \$3.00 a year. Individual copies, \$.25 in the United States and possessions; Canada and foreign countries, \$.30. Published by Standard Publications, Inc., 4600 Diversey Avenue, Chicago, Illinois. Editorial and advertising offices, 1123 Broadway, New York, N. Y. Louis Martin, President; Robert Hertzberg, Secretary-Treasurer; Charles H. Farrell, Advertising Manager.

SHORT WAVE RADIO is distributed by Mutual Magazine Distributors, Inc., 53 Park Place, New York, N. Y.

Articles on short-wave subjects are desired, and are paid for on publication. The editors will be glad to discuss contributions with authors. Unused or unsolicited manuscripts will not be returned unless full postage is furnished by the contributor.

Address all correspondence of editorial or advertising nature to SHORT WAVE RADIO, 1123 Broadway, New York, N. Y. Telephone: CHelsea 2—6620 and 6621.

SINGLE CONTROL

FOR AMATEUR PHONE SHORT-WAVE STANDARD BROADCASTS



You'll enjoy the simplicity with which the new G-E short-wave sets can be used. There is only one tuning control and no coils to change.

In the all-wave models two tuned R.F. stages on the 8-18 megacycle band eliminate image frequency response. On the other bands one stage is used. Frequency range on 4-band all-wave models:

- (A) 540-1500 KC (B) 1500-3900 KC
- (C) 3900-10000 KC (D) 8000-18000 KC

On 2-band dual-wave models:

- (A) 450-1500 KC (B) 5400-15350 KC

Accurate tuning is assured by the airplane-type illuminated dial accurately graduated in kilocycles and megacycles. Short-wave broadcast ranges are marked on the dial in meters.

You can safely recommend these G-E short-wave sets to your non-technical friends. Their performance is good and they are easy to operate.

With these sets, and a simple, single-tube oscillator, you can receive continuous wave. Diagrams of the oscillator and instructions for making it will be sent upon request.



All-wave Model K-80. Price \$92.50



Dual-wave Model K-64
Price \$58.50



Dual-wave Model M-65
Price \$79.50

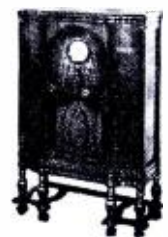

All-wave Model K-85
Price \$128.75

Price slightly higher West and South. Subject to change without notice.

Radio Sales Section R-686.
GENERAL ELECTRIC COMPANY
Merchandise Department
Bridgeport, Conn.

Please send me free of charge: diagram and instructions on C. W. oscillator.

Name _____

Address _____

City _____ State _____

GENERAL ELECTRIC RADIO



Byrd Antarctic Programs Successful

THE most isolated short-wave broadcast station in the world, KFZ, was established by Rear Admiral Richard E. Byrd and his radio aides in Little America on February 1st, 1934. The first Antarctic program transmitted from KFZ by short waves and rebroadcast in the United States over the nationwide network of the Columbia Broadcasting System took place on February 24th. For sheer dramatic interest, the regular 10 o'clock Saturday night programs that followed have few equals in the history of radio broadcasting. They reached what is probably a grand climax on March 17th, when Joseph Pelter, the expedition's aerial surveyor, addressed the microphone after successfully going through an emergency appendectomy, which was performed right in the radio shack.

The transmitter being used at Little America is the same Collins 1-kw. outfit previously used under the call letters KJTY on the *S. S. Jacob Ruppert*, the ship that brought the members of the Second Antarctic Expedition to their destination. An account of the preliminary activities of the Expedition will be found in the January, March and April (1934) issues of *SHORT WAVE RADIO*.

Directional Aerial Used

KFZ uses a tricky directional antenna aimed at Buenos Aires, Argentina. Here the signals are picked up by a special diversity array (see page 4, April issue) and retransmitted to the United States via station LSX. In the States, the LSX signals are picked up at the RCA-Communications receiving station at Riverhead, L. I., which was fully described in the April, 1934, issue. The signals are then shot by land line to the CBS headquarters at 485 Madison Avenue, New York, and from there re-routed to the WABC transmitter at Wayne, N. J., and the various other transmitters of the CBS chain.

Riverhead is able to pick up KFZ directly with excellent quality and volume, but this direct link is considered more as an emergency channel than as anything else. Koko Head, Hawaii, has also been standing by KFZ.

Signals Are Re-transmitted

One of the interesting angles of the special Saturday night programs is that the signals received at Riverhead by way of Buenos Aires are also sent by land line to one of the RCA-Communications short-wave transmitting stations at Rocky Point, L. I., and re-transmitted from there. The radio operators in Little America tune in this station and thus are able to hear their own programs over

what is undoubtedly the longest two-way radio circuit in the world. This reception, incidentally, affords them an opportunity to check the quality of the eventual KFZ program in the United States.

Many listeners in the United States have been able to tune in the short-wave signals from KFZ directly, but many others have been fooled very badly by these Rocky Point re-transmissions. As the Long Island station uses something like twenty kilowatts of power, it puts a terrific signal into local receivers. Listeners are therefore cautioned to wait patiently for final announcements.

No Verifications

Neither the Columbia Broadcasting System nor RCA-Communications verifies reports of reception, as they consider this program interchange of a private nature, although there certainly is nothing less private than a radio broadcast! "Veri" fans should therefore save their stamps and be satisfied with the reception itself, which is highly interesting.

Besides the directional antenna aimed at Buenos Aires, there are a half-dozen or more regular antennas for various frequencies. These are used by KFZ for radio telegraphic communication with Mackay commercial stations and amateur stations in the United States. John N. Dyer, engineer-in-charge of communications for the whole expedition, is himself a well-known amateur and undoubtedly his contacts with some of his friends in the United States do much to make up for the rigors of Antarctic life. The directional antenna is tuned roughly in the neighborhood of 9 megacycles, and can be tuned either above or below this value in order to meet transmitting conditions between Little America and Buenos Aires. Incidentally, Little America is seven hours earlier than New York, which means that when it is 10 o'clock in the evening standard New York time, it is only 3 o'clock in the afternoon down on the ice pack.

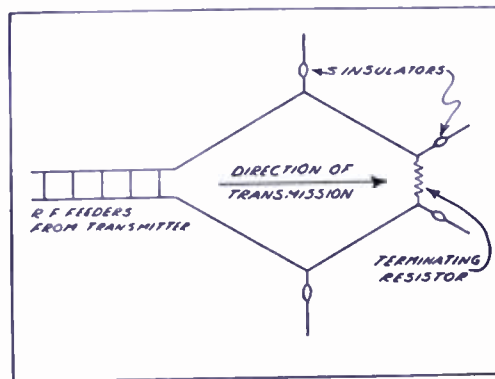

Plan view of the directional antenna used by station KFZ for its short-wave program transmissions.

KFZ tests with Buenos Aires and the United States every Friday night and also just before the 10 o'clock programs on Saturday night. Short-wave listeners who want to fish for this most interesting of all catches should guide themselves accordingly. It is difficult to state a particular frequency that is likely to be heard best. During the early part of the year, up to the end of March, a frequency in the neighborhood of 13 megacycles (23 meters) proved most satisfactory. Complete lists of the frequencies assigned to KFZ by the Federal Radio Commission will be found in the early articles in *SHORT WAVE RADIO*, as previously mentioned.

An interesting sidelight of the trip of the *Jacob Ruppert* from Panama to New Zealand was revealed recently by A. B. Chamberlain, chief engineer of the Columbia Broadcasting System, under whose auspices the broadcasting is being done. It was Byrd's original intention to head straight for Little America, with only an incidental stop at Easter Island, which is located in the Southern Pacific, just below the Tropic of Capricorn and about 2000 miles off the west coast of South America. Instead, however, he headed for Wellington, N. Z. Here the ship docked in a location that appeared to be absolutely hopeless from the short-wave radio standpoint. However, a special program originating in a New Zealand studio and carried by wire line to KJTY at the dock was transmitted by short waves to Honolulu, re-transmitted by radio to San Francisco, relayed by a land line to New York and then rebroadcast over the CBS network. In spite of the total length of the jumps, the program came through with a rating of 80% perfect. This stunt was accomplished on December 9th, 1933.

Medal for Byrd

The success of the Antarctic broadcasts has moved the Columbia Broadcasting System to award its 1934 medal for "Distinguished Contribution to Radio" to Rear Admiral Byrd. Only five other persons previously received this award. They are Charles Lindbergh; Sir John A. Reith, Director General of the British Broadcasting Corp.; Leopold Stokowski, conductor of the Philadelphia Orchestra; Amelia Earhart; and Nino Martini, Metropolitan Opera tenor. Presentation of the medal was made on March 31st by Henry A. Bellows, vice-president of CBS, during a special broadcast directed to KFZ and transmitted to Little America by short waves. Admiral Byrd's acceptance speech came back by way of the KFZ-Buenos Aires-New York link previously described.

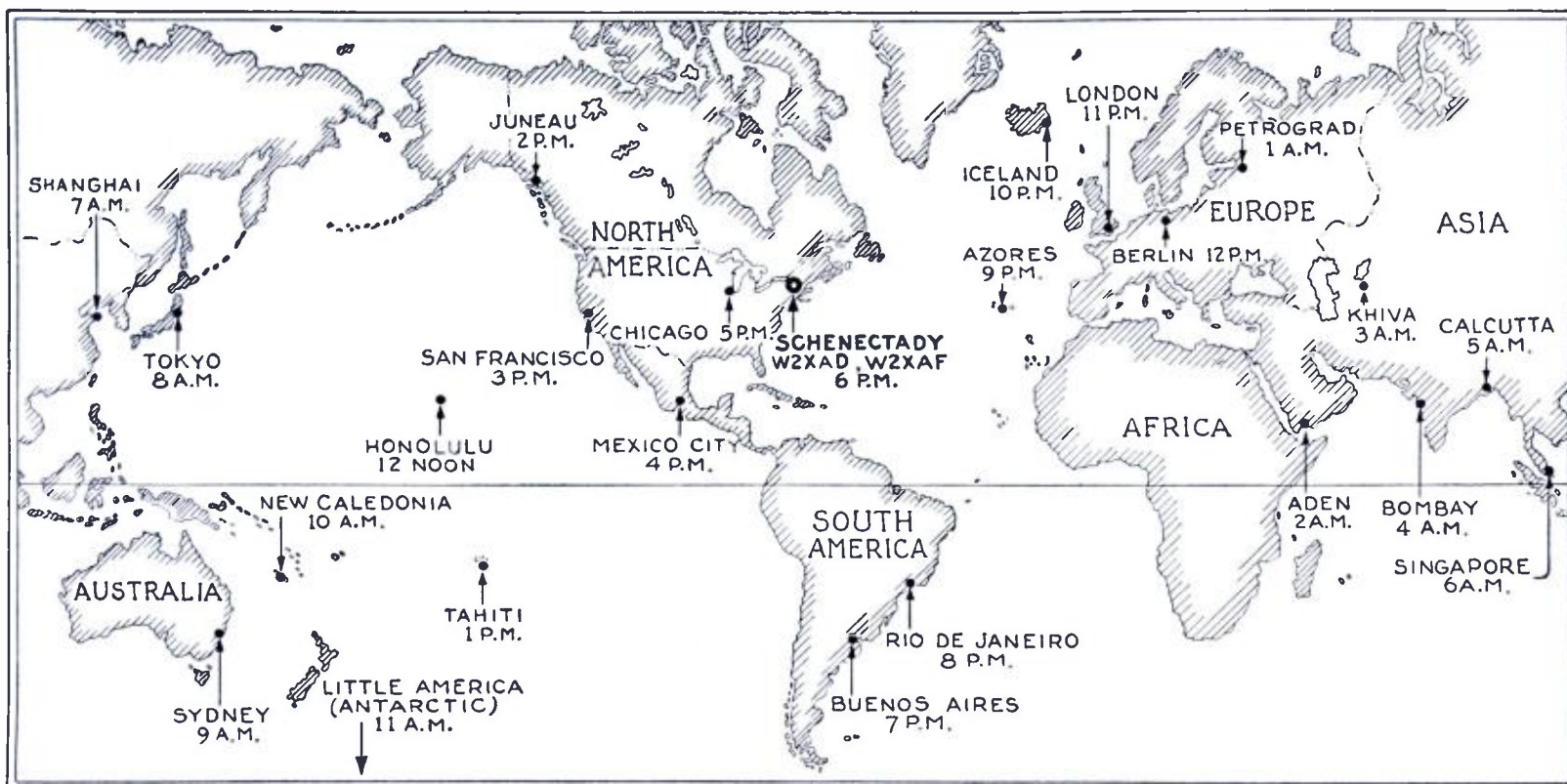

This map of the World shows the time in various cities when it is 6.00 p.m. in Schenectady, N. Y.

Unique 1-Hour Program Covers World

TWENTY-FOUR hours of broadcasting in 10 or more different languages, all crowded into a single hour, constituted a radio program sent by short wave stations W2XAF and W2XAD, in Schenectady, on Friday night, March 16. This broadcast "to the world" was also unique in that it was the first attempt to reach the four corners of the globe from a single station without relays in foreign countries.

The program opened at 6 o'clock, E.S.T., and continued one hour. It was heard in practically all parts of the world, as expected. When it was Friday and 6 P.M. in Schenectady it was—

- 7 P.M. in Buenos Aires
- 8 P.M. in Rio de Janeiro
- 9 P.M. in Azores
- 10 P.M. in Iceland
- 11 P.M. in London
- 12 P.M. in Berlin

SATURDAY—NEXT DAY

- 1 A.M. in Leningrad
- 2 A.M. in Aden, Arabia
- 3 A.M. in Khiva, Turkestan
- 4 A.M. in Bombay
- 5 A.M. in Calcutta
- 6 A.M. in Singapore
- 7 A.M. in Shanghai
- 8 A.M. in Tokio
- 9 A.M. in Sydney, Australia
- 10 A.M. in New Caledonia Islands
- 11 A.M. in Little America

FRIDAY—SAME DAY

- 12 Noon in Honolulu
- 1 P.M. in Tahiti
- 2 P.M. in Juneau, Alaska
- 3 P.M. in San Francisco
- 4 P.M. in Mexico City
- 5 P.M. in Chicago

This broadcast was also received in all seasons of the year at the same

time, so that it was quite fitting that "Believe It or Not" Ripley, world famous cartoonist, who has visited some 164 different countries in his travels, should be selected for the spokesman for this epochal broadcast. His speech was in several parts, each pertaining to "believe it or not" of a particular race, and immediately after he spoke, his words were translated into the native language of that country and broadcast. Among the races addressed were the German, French, Russian, Scandinavian, Spanish, Portuguese, Chinese and Japanese. Listeners were asked to write the General Electric Company, stating the time of day they heard the program and how well it was understood.

Keep a Log

TOO many short wave experimenters depend entirely upon their memory for the dial settings of the more important short wave broadcasters. Every listener should keep a "log" even if the listings have to be kept on a piece of paper.

Many different methods of listing are possible. Some listeners arrange their stations by countries. Others prefer to list them by the day and hour. Still others arrange their catches as to the wavelength or frequency in kilocycles, depending upon the type of dial used. However, regardless of what method is used, if a "log" is kept it will enable one to set the dials so that the stations may be spotted easily and quickly.

The special log sheets made up by SHORT WAVE RADIO are recommended

Ripley drew a special cartoon as a souvenir for this broadcast and to all persons outside of the United States who write General Electric that they heard this program a copy of this will be mailed.

This was the first time a broadcast such as this has ever been tried. The two short-wave transmitters have been heard in almost every country at different times on different programs but this was the first time an attempt was made to reach all countries with a single broadcast, not relayed by any foreign stations. W2XAF, operating on 31.48 meters, or 9530 kilocycles, is used for evening broadcasts, and W2XAD, operating on 19.56 meters, or 15,330 kilocycles, is used for daytime broadcasts.

for their convenience. However, even a dime school note-book will serve the purpose.

Regarding the S. A. Stations

Many of the Spanish speaking stations in Central and South America are really not broadcasting stations at all, but amateurs. The regulations covering short-wave operation in some of these countries are not nearly as strict as they are in the United States. Some of these stations even pick their own wavelengths, quite without regard for the International Service assignments.

American amateurs are strictly prohibited from "broadcasting" entertainment or talks of general public interest, although they may send phonograph music, to a limited extent, for testing purposes.

Foreign Program Notes of Interest

PHI on Regular Schedule

PEOPLE who owned short-wave receivers four or five years ago will remember Edward Startz, the versatile announcer of the famous station PCJJ, later PCJ, the pioneer short-wave broadcasting station at Eindhoven, Holland, operated by N. V. Philips Company. They will be interested to learn that he is back on the air through another Philips station, PHI. We quote a letter from him dated March 16, 1934.

"Kindly note that station PHI is regularly on the air five days a week with the exception of Tuesday and Wednesday. The hours are 1300 to 1530 G.M.T. (8.00 to 10.30 P.M., Eastern Standard Time). The present wavelength is 25.57 meters until the month of May, when we will change to 16.88 meters for the summer months.

"It might interest you to learn that we are receiving regularly reports from all over the U. S. Letters from large cities of course are few in comparison with reports coming from smaller places."

U.S.S.R. Phone Stations

WE are indebted to the New Zealand Short Wave Club for the two excellent lists of Soviet short-wave stations that follow:

COMMERCIALS USING VOICE (All 20 kilowatts)

RRLY	16.10	metres	Irkutsk
RIM	19.67	"	Tashkent
RKI	19.95	"	Moscow
RKS	24	"	Irkutsk
RRH	30.40	"	Tashkent
RKI	39.89	"	Moscow
RIS	43.64	"	Tiflis
RJZ	50.90	"	Tiovaiskoe
RRH	16.73	"	Tashkent
RAU	19.85	"	Tashkent
RPK	20.76	"	Moscow
RRLY	30.20	"	Irkutsk
RIM	39.34	"	Tashkent
RPK	41.50	"	Moscow
RDA	45	"	Odessa
RJY	53.57	"	Sinelorkovo

BROADCASTING STATIONS

(Power in kw. in brackets)			
RTM	(15)	16.32 met.	Khabarovsk
RIM	(20)	19.67	Leningrad
RKK	(20)	24.45	Moscow
RTM	(15)	25.38	Khabarovsk
RBM	(10)	32.47	Kharkov
RFM	(20)	72	Kharbarovsk
RRF	(20)	16.66	Leningrad
RPK	(20)	20.76	Moscow
RNE	(20)	24.45	Moscow
RRF	(20)	29.14	Leningrad
RNE	(20)	50.00	Moscow

According to the excellent little mimeographed bulletin of the N. Z. S. W. Club, we also learn that the following stations will not verify

This department, which will be expanded in future issues, is of particular interest to DX fans, recent purchasers of all-wave receivers and s.w. set owners whose primary interest is tuning. The information it contains is reliable and authentic, and is based on verified reception reports, communications received directly from the stations concerned, or other sources whose dependability is known to the editors.

reports of reception: British and German ships; CEC, Chile; HJB and HJY, Colombia; HPF, Panama; KKP Hawaii; OCI, Peru; PPU, Brazil; PSF, Brazil; WNC, U. S. A., ZFB, Bermuda; and J1AA, Japan.

Canadian Call Changed

An official communication from Winnipeg states that the call of VE9JR has been changed to CJRX. Station VE9GW sends on the following schedule (E.S.T.):

Sunday, 11:30 A.M.—8:00 P.M.
Monday, Tuesday, Wednesday,
2:00 P.M.—11:00 P.M.
Thursday, 3:00 P.M.—12:00 MID.
Friday, Saturday, 8:00 A.M.—
12:00 MID.

Station COC, Havana, Cuba, states that they are on 49.9 meters or 6010 kc., not 50.2 meters as commonly listed.

New Oriental Stations

A number of new stations in the Orient have been reported recently. Among the more important ones are CQN, Macao, China, which is supposed to be using 500 watts of power on 49.8 meters. Two new Japanese stations are JYK on 21 meters, and JYS on 30.4 meters. These have been



A recent photograph of Edward Startz, versatile announcer of Station PHI.

heard only between about 4:30 and 6 A.M., E.S.T.

Station PLW in Bandoeng, Java, on 31.6 meters, occasionally transmits music for test purposes when working Amsterdam.

Sponsored S.W. Programs?

The American short-wave listening audience has been increasing to such an extent that at least one enterprising American firm is trying to arrange for sponsored programs over a European short-wave station that is heard regularly in the United States. We understand that this will be EAQ, in Madrid.

At least one day a week during the spring EAQ will broadcast greetings to the representatives of an American radio set manufacturer.

It is hoped that this sort of thing will not become too prevalent, as American listeners get enough advertising talk over our own domestic stations. In fact, some of the newspaper radio critics ascribe part of the present popularity of short-wave reception to the fact that it allows listeners an escape from inane sponsored "entertainment."

B.B.C. Adopts 24-Hour Clock

SHORT-WAVE listeners who are confused by time differences between various parts of the world will be interested to learn of a move made just recently by the British Broadcasting Corporation, which controls all broadcasting activities in Great Britain. We quote directly from *World Radio*, the official weekly organ of the B. B. C.:

"The question of the adoption in Great Britain of the twenty-four-hour method of time notation, like the metric system, has long been a subject of periodic discussion. Nevertheless the fact that that system has been applied, and found to work well, by H. M. Services, by Imperial Airways throughout the world, by British railways in their Continental time-tables, by the International Exchange of the G. P. O., and by certain European broadcasting organizations, is regarded by many persons as irrelevant to the argument that it should be generally adopted in this country.

"Whether or not the new time notation be eventually put into general use, the B.B.C. intends to adopt the system experimentally for its own purposes; and from April 22 next, when Summer Time begins, Broadcasting House, together with the Regional stations, studios, and offices, will forsake—anyhow, during the experimental period—the twelve-hour clock, and in its microphone announcements and its journals the new timing will be applied.

"There will, of course, be those
(Continued on page 39)

Best Short Wave Stations

The list below has been compiled from various sources, which have been checked up as closely as the difficulties of international correspondence permit. While it is not 100% accurate (no s.w. station lists of any kind are!), it will be found very useful as a foreign station tuning guide.

The figures at the extreme left are wavelength in meters; next month, for the convenience of all-wave set owners, we will convert these into megacycles. Readers are invited to send in additions or corrections based on their own reception experiences.

World wide stations that send programs, B, Broadcast; E, Experimental; P, Telephone stations.

Europe

- 16.30, P, PCK, Kootwijk, Holland, about 6.30 a.m.
 16.86, B, GSG, Daventry, England, 7.30 to 8.45 a.m.
 16.88, B, PHI, Hilversum, Holland. Daily except Tuesday and Wednesday, 8.00-10.30 a.m.
 19.55, B, CTIAA, Lisbon, Portugal. Tuesday and Friday, 4.30 to 7 p.m.
 19.68, B, Pontaise, France, 8 to 11 a.m.
 19.73, B, DJB, Berlin, Germany, 10.00 a.m. to 4.30 p.m.
 19.82, B, GSF, Daventry, England, 3 to 5 a.m.
 19.84, B, HVJ, Vatican City, Italy, 5 to 5.30 a.m.
 25.00, B, RNE, Moscow, U.S.S.R., 8.30 to 10.00 a.m. Saturday.
 25.20, B, Pontaise, France, 11.15 to 2.15 p.m., 3 to 6 p.m.
 25.28, B, GSE, Daventry, England, 7.30 to 8.45 a.m. and 4 to 6 p.m.
 25.40, B, I2RO, Rome, Italy, 11.30 a.m. to 6.00 p.m. daily. Woman announcer.
 25.51, B, DJD, Berlin, Germany, 1.30 to 7.30 p.m.
 25.53, B, GSD, Daventry, England, 3 to 5 a.m., and 1.15 to 2.45 p.m.
 25.57, B, PHI, Huizen, Holland.
 25.63, B, Pontaise, France, 3 to 6 and 6.15 to Midnight.
 29.04, Ruysselede, Belgium, 1 p.m. on.
 30.00, B, EAQ, Madrid, Spain, 5.15 to 7 p.m.
 30.52, B, IRM, Rome, Italy, 2 to 6 p.m.
 31.27, B, HBL, Geneva, Switzerland, Sat. 5.30 to 6.15 p.m.
 31.30, B, GSC, Daventry, England, 6 to 8 p.m.
 31.38, B, DJA, Berlin, Germany, 5.00 to 9.00 p.m.
 31.55, B, GSB, Daventry, England, 11.30 a.m. to 12 p.m., 1.00 to 5.30 and 6.00 to 8.00 p.m. daily.
 43.86, HAT2, Budapest, Hungary, irregular. No time schedule.
 45.38, B, RNE, Moscow, Russia, 2 to 6 p.m.
 49.50, B, OXY, Skamleback, Denmark, 2 to 6 p.m.
 49.59, B, GSA, Daventry, England, 2.45 to 5.45 p.m., 6 to 8 p.m.
 49.83, B, DJC, Zeesen, Germany, 8 to 11 p.m.
 50.00, B, RV59-RKF, U.S.S.R., 2.00 to 5.00 p.m. daily.
 50.26, B, HVJ, Vatican City, Italy, 2 to 2.15 p.m.
 60.30, E, G6RX, Rugby, England, 8 to 10 p.m., irregular.
 69.44, E, G6RX, Rugby, England, 9 to 11 p.m., irregular.

Asia

- 16.50, P, PMC, Bandoeng, Java, 3 to 5 p.m., irregular.
 19.03, E, JIAA, Kemikawa, Japan, 4.30 a.m., irregular.
 20.03, P, KAY, Manila, Philippine Isl., 5 to 8 a.m.

- 30.40, E, JIAA, Kemikawa, Japan, 5 to 7 a.m.
 48.90, B, ZGE, Zula Lumper, Malayan States, Sun., Tues., Fri., 6.30 to 8.30 p.m.
 49.10, B, VUC, Calcutta, India, 9 to 12 a.m. and 2 p.m. to 3 a.m.

Africa

- 23.38, B, CNR, Rabat, Morocco, Sun., 7.30 to 9 a.m.
 29.58, P, OPM, Leopoldville, Belgian Congo, 9 to 10 a.m.
 37.33, B, CNR, Rabat, Morocco, Sun., 3 to 5 p.m.
 41.60, B, EAR58, Teneriffe, Canary Isl., 5 to 6 p.m.
 48.99, B, Johannesburg, South Africa, 4 to 5 a.m., 12 to 3 p.m., and 8 to 10 a.m.
 49.50, B, VQ7LO, Nairobi, Kenya, 11 a.m. to 2 p.m.

North America

- 16.87, B, W3XAL, Bound Brook, N. J., 10 a.m. to 4 p.m., irregular.
 19.56, B, W2XAD, Schenectady, N. Y., Man., Wed., Fri. and Sun., 4 to 5 p.m.
 19.64, B, W2XE, Wayne, N. J., 11 a.m. to 1 p.m.
 19.67, B, WIXAL, Boston, Mass., 11 a.m. to 3 p.m., Sun.
 19.72, B, W8XK, Pittsburgh, Pa., 10 a.m. to 4 p.m., irregular.
 25.27, B, W8XK, Pittsburgh, Pa., 4.30 to 10 p.m., irregular.
 25.36, B, W2XE, Wayne, N. J., 3 to 5 p.m.
 25.45, B, WIXAL, Boston, Mass., Sat., 5 to 11 p.m., and Sun. 6 to 8 p.m.
 31.28, B, W3XAU, Philadelphia, Pa., 1 to 6 p.m.
 31.36, B, WIXAZ, Springfield, Mass., 7 p.m. to 1 a.m.
 31.48, B, W2XAF, Schenectady, N. Y., 8 to 11 p.m.
 46.69, B, W3XL, Bound Brook, N. J., irregular.
 48.86, B, W8XK, Pittsburgh, Pa., 4.30 p.m. to 1 a.m.
 49.02, B, W2XE, Wayne, N. J., 6 to 11 p.m.
 49.18, B, W3XAL, Bound Brook, N. J., Sat. 4.30 to 12 p.m.
 49.18, B, W9XF, Chicago, Ill., 8 to 9.30 p.m.
 49.34, B, W9ZAA, Chicago, Ill., 3 to 6 p.m.
 49.50, B, W3XAU, Philadelphia, Pa., 8 to 12 p.m., irregular.
 49.50, B, W8XAL, Cincinnati, Ohio, 9 to 10 p.m.

South America

- 19.19, P, OCJ, Lima, Peru, 2 p.m. irregular.
 25.73, E, PPQ, Rio de Janeiro, Brazil, 7 p.m., irregular.
 27.35, P, OCI, Lima, Peru, 10 p.m., irregular.
 28.98, E, LSX, Buenos Aires, Argentina, 8 to 9.30 p.m., irregular.
 30.03, E, LSN, Buenos Aires, Argentina, 9 to 10 p.m., irregular.

- 32.00, B, Ti4NRH, Costa-Rica, 7 to 8 p.m.
 32.8, B, CP5, Bolivia, 7.30 to 10.30 p.m.
 36.65, E, PSK, Rio de Janeiro, Brazil, 8 p.m., irregular.
 40.55, E, HJ3ABD, Bogota, Colombia, 9 to 11 p.m.
 41.55, B, HKE, Bogota, Colombia, Mon. 6 to 7 p.m. and Tues. 8 to 9 p.m.
 41.60, B, HJ4ABB, Manizales, Colombia, 9 to 10 p.m.
 45.00, B, HC2RL, Quito, Ecuador, Sun. 5 to 7 and Tues. 9 to 11 p.m.
 45.31, B, PRADO, Riobamba, Ecuador, Thurs. 9 to 11 p.m.
 45.60, B, HJ1ABB, Barranquilla, Colombia, 6 to 10 p.m.
 47.00, B, HJ5ABD, Colombia, Thurs., Sat. and Sun., 7 to 9.30 p.m.
 48.00, B, HJ3ABF, Bogota, Colombia, 7 to 10.30 p.m.
 48.50, B, TGW Guatemala, 6-12 p.m.
 48.78, B, YV3BC, Caracas, Venezuela, Evening, irregular.
 48.95, B, YV11BMO, Maracaibo, Venezuela, 8 to 11 p.m.
 49.39, B, YV5 BMO, Maracaibo, Venezuela, 5 to 9 p.m.
 50.20, B, YV1BC, Caracas, Venezuela, 5 to 10 p.m., irregular.
 50.20, B, HJ4ABE, Tunga, Calambia, 9 to 10.30 p.m.
 73.00, B, HCJB, Quito, Ecuador, Evening, irregular.

Mexico, West Indies, and Yucatan

- 25.50, P, XDM, Mexico City, Mexico, 8 to 9 p.m., irregular.
 26.00, E, XAM, Merida, Yucatan, 6 to 7 p.m. irregular.
 32.09, E, XDC, Mexico City, Mexico, 5 to 7 p.m., irregular.
 47.50, B, HIZ, Santa Domingo, 5 to 6 p.m.
 47.80, B, H11A, Dominican Republic, Mon., Wed. and Fri. 12 to 1.30 p.m. Tues., Thurs. and Sat. 7.30 to 9.30 p.m.
 B, HIX, Santo Domingo, Tues. 8 to 10 p.m.
 50.2, B, COC, Havana, Cuba, 5 to 6 p.m.
 50.2, B, YV4 BAG, Caracas, Venezuela, 12.50 to 1.05 a.m.

Oceania

- 31.28, B, VK2ME, Sydney, Australia, Sun. 1 to 3 a.m., 5 to 8.30 a.m., and 9 to 11 a.m.
 31.55, B, VK3ME, Melbourne, Australia Wed. 5 to 6.30, Sat. 5 to 7 a.m.

Canada

- 25.60, B, VE9JR, Winnipeg, Canada, 6 to 10 p.m., irregular.
 49.10, B, VE9HX, Halifax, N.S., Evening, irregular.
 49.22, B, VE9GW, Bowmanville, Canada, 3 to 6 p.m. daily.
 49.29, B, VE9BJ, St. John, N. B., 5 to 10 p.m.
 49.42, B, VE9CS, Vancouver, B.C., Fri. 12 to 1.30 p.m.
 49.96, B, VE9DR, Montreal, Canada, 8 to 10 a.m., Sun 1 to 10 p.m.

NOTE: All times given are Eastern Standard.

Reception Reports From Readers

BECAUSE the United States is a big country, reception conditions on the short waves are bound to be different in different sections. For this reason, we ask readers to send in detailed reports of their experiences. Extremely interesting data have been brought to light in some of the letters we have published. This department has caused many short-wave listeners to start corresponding with each other, and some fine friendships have been built up.

If you have been keeping a log of your results (and every listener should), by all means send us a sort of review of it for a period of, say, a month. Don't fail to mention your receiver and to describe your aerial. Use a typewriter if you have one; otherwise, please write clearly in ink on one side of the paper.

California

I have followed your reports in SHORT WAVE RADIO and have found them of great assistance. However, as the reports are of reception on the East Coast, they do not always apply out here, a great many of the stations listed not being received here, although as I have been listening only a few months, I do not claim to have tuned for them all.

I hope you will receive enough reports from the West Coast to enable you to present a list in SHORT WAVE RADIO for this area; it would be a great help to the beginners and a source of comparison for the old-timers.

My receiver is a National FB7A, and performs very well. I am going to add the pre-selector, hoping to boost the gain a little. The aerial is a transposed doublet, 78 feet each side of center.

I listen almost always during the daytime, and, consequently, the stations heard are on the high frequencies. I have only an occasional few minutes between 5.30 and 9 p.m., P.S.T., to spend with the set, and after that there is little if anything to be heard except eastern locals on 6 meg. which sign off about 9.30 or 10 p.m.

I will list the stations by frequencies; all time, Pacific Standard.

GSE, 11865 kc., GSD, 11750 kc., heard according to schedule, fair volume. GSC, 9585 kc., GSB 9510 kc., usually much fainter.

Pontoise, 11905 kc., good volume.

EAQ, 9862 kc., formerly loud and clear, not heard lately so consistently.

No other European stations have been heard.

XETE, 9600 kc., has been heard quite often during the last two weeks between 6 and 7 p.m.

HJ1ABB, about 6500 kc., formerly heard daily 6-7 p.m., is no longer heard.

LSY, 10400 kc., the Byrd program. Another station in Buenos Aires transmits program material to CBS, (Columbia Broadcasting System), on about 20,000 kc., but have not heard the call letters given.

Several other South American stations have been heard but the call letters could not be distinguished; all speech was Spanish.

VK2ME and VK3ME are always heard on schedule with good volume when conditions are favorable.

PLE, 18820 kc., phones Dixon, Calif., Fri. 4 p.m., very loud signal.

KAZ, 9990 kc., phones KWX, Dixon, daily at 7.30 a.m., loud signal.

A Japanese station on about 8000 kc. is heard in the early morning.

JYK, JYT, and JQJ phone Hawaii and Bolinas and Point Reyes, Calif., irregularly, and also transmit program material to CBS at the same receiving stations. JYK has been heard phoning Australia on about 13500 kc. at 10 p.m. JYT has a frequency of 10773 kc., and JQJ uses 13220 kc. and 12900 kc. although only the former has been heard.

A Russian on about 4200 kc has been heard in the early morning with a very strong signal, possibly RV15.

KKH, 7520 kc., KEJ, 9020 kc., KKP, 16040 kc., and K10, 11670 kc. are heard almost daily either phoning, testing or transmitting program material to CBS or NBC. When testing they frequently use the call K6XO. Their signals are very loud, of course.

VE9GW, 6095 kc., is heard in the early mornings about daylight, and from 5 p.m. till they sign off. There is usually interference from code stations.

CJRX, 11760 kc., formerly VE9JR, daily from about 5.15 p.m. till 7 p.m.

VE9GN, 6005 kc., (Canadian Marconi Ltd., Montreal) transmits CRC's programs to the Arctic Sat. 8.30-9 p.m. VE9GW, CJRX, and CJRO (Winnipeg), 6147 kc. transmit the same program; the latter has not been heard.

CFU in British Columbia tests irregularly on about 11 meg. but its frequency and location have not been ascertained.

KEE, 7717 kc., KEZ, 10410 kc., KWZ, 10480 kc., KKW, 13780 kc., KKZ, 14150 kc., KWO, 15419 kc., KWE, 15420 kc., at Dixon and Bolinas, Calif., are heard daily phoning or transmitting program material. The call, W6XI, is sometimes used when testing. I omitted

above KWX 7610 kc. by mistake.

WVD, 6618 kc., is testing for a phone circuit to Alaska; it is located in Seattle.

Many eastern phone stations are heard, as well as some in Europe and South America, but few are identified. WEM, 7400 kc., WCN, 5070 kc., WEF, 9590 kc., WMA, 13390 kc., WMN, 14580 kc., WNC, 15055 kc., WLK, 16330 kc., are heard irregularly.

KNRA on about 13 meg. has been heard once but very faintly.

The eastern "locals" are all heard, or twelve of them to be exact; the high frequencies during the daytime, and around 6 meg. in the evening; twenty different frequencies have been logged, and I do not enumerate them here lest this report be too lengthy, and I am afraid it is beyond that qualification already.

Hoping to see something for the West coast listener in SHORT WAVE RADIO, I remain,

Very truly yours,

JAS. C. HAYES,

Box D. San Rafael, Cal.

March 21, 1934.

Eastern Pennsylvania

While conditions here in eastern Pennsylvania do not, of course, vary much from those in the neighborhood of New York, you may be interested to hear that with a Model 16-X Philco All-Wave receiver I have tuned in all the stations your recent articles mention except RV59, Moscow. I should say that I have not made any particular effort to receive that one, but shall pay a little attention to it now in line with your suggestions.

I have been interested in the short waves for a considerable time but have never got around to "doing anything about it" until recently. I have been skeptical of the converters as well as the all-wave sets, most of which I have tested more or less fully. Needing a new broadcast receiver this winter I concluded to try a Philco, as above. I am too busy with my job to find time for building receivers. I have been pleasantly surprised with its efficiency. Not being a ship model builder like Capt. Hall, nor engaged in any other pursuits that keep me awake till the early morning hours, I have had to resort to the alarm clock to enable me to tune in VK2ME, Sydney, Australia. However, this commercial receiver does the trick, although when I have tried it the reception was not too strong.

Occasionally I find here a period of two or three days when even DJB, 19.73, GSD, 25.53, and 2RO, 25.40, are not worth listening to, although they can be heard sufficiently clear for identification. However, on the

whole, I can be reasonably sure about five days a week of excellent reception. Tonight I had both GSA, 49.59, and DJC, 49.83 meters, coming in as satisfactorily as Chicago stations on the broadcast band. I2RO has recently been coming in very strong, also EAQ, which never fails me. I should have to say that while their signal is strong, EAQ's broadcast has much distortion.

I have not yet got around to building a real antenna. I am using a 25-foot straight-line antenna which was put up for a receiver located on the second floor of my home. I merely spliced about thirty feet of lead-in wire onto the lead-in for upstairs set and connected it to the Philco set on the ground floor. This, I find, serves better than a 75-foot antenna that was previously built for another set located where the All-Wave is now located. I am going to construct in the near future a new antenna along the lines of recent suggestions in SHORT WAVE RADIO and other publications.

Yours very cordially,
H. E. MITCHELL,
1525 Dauphin Ave.,
Wyomissing, Pa.

Omaha, Nebraska

NOTICE in SHORT WAVE RADIO for April a letter from D. M. Paul, Edgeley, N. D., telling of the very poor reception of foreign stations in the Middle West. Omaha is pretty much in the Middle West, only somewhat south of North Dakota, but this should in no way improve reception on short-wave sets. Am located in a city of a quarter million people, a short one-half block from surface cars and on a through street with plenty of man-made interference. However, I purchased on January 1st, 1934, one of the new type RCA-Victor all-wave sets, using a 75' outside aerial with very good results, stations coming in fine from early a.m. to late p.m. daily: London to 6 p.m., Madrid to 6 and 7 p.m., Rio from 5:45 to 6:30 and Berlin to 9 and 10 p.m. and a half dozen South American stations 'til late p.m. Will give you a list of stations we receive regularly (not including U. S. and Canadian, as they are like locals):

PSK Rio de Janeiro, So. A.
GSB Daventry, England
GSC Daventry, England
GSD Daventry, England
GSE Daventry, England
GSF Daventry, England
GSA Daventry, England
EAQ Madrid, Spain
CP5 La Paz, Bolivia, So. A.
HKC Bogota, Colombia, So. A.
HKE Bogota, Colombia, So. A.
FYA Paris, France
DJA Berlin, Germany
DJD Berlin, Germany
DJB Berlin, Germany
DJC Berlin, Germany
XETE Mexico City, Mex.
KKH Honolulu, Hawaii
PRADO Riobamba, Ecuador, S. A.

Vineland, N. J.—A Fine List of Stations

In the April issue of SHORT WAVE RADIO I noticed a letter from Mr. D. M. Paul. He states that out in Edgeley, N. Dak., they don't have any luck on the higher frequencies after dark. Reception conditions here are different. At the present time Germany uses DJD on 25.51 meters from 8:00 P.M., to 11:00 P.M., E.S.T. Pontoise on 25.63 meters use this wave at 10:00 P.M., and both of these stations come in fairly well.

During August, 1933, England used GSF on transmission five from

<i>Argentina</i>		<i>Germany</i>		<i>G6RX—</i>	69 meters
LSN—	20 meters	DIQ—	29 meters	<i>Italy</i>	
LSX—	28 "	DJA—	31 "	HVJ—	19 "
LSN—	30 "	DJB—	19 "	I2RO—	25 "
<i>Australia</i>		DJC—	49 "	<i>Mexico</i>	
VK2ME—	31 meters	DJD—	25 "	XETE—	31 meters
VK3ME—	31 "	DGK—	44 "	XAM—	26 "
<i>Brazil</i>		<i>Great Britain</i>		<i>Morocco</i>	
PSK—	36 meters	GBU—	24 meters	CNR—	37 meters
<i>Canada</i>		GBW—	20 "	<i>Portugal</i>	
VE9GW	49 meters	GCU—	30 "	CT1AA—	31 meters
VE9JR—	25 "	GCW—	30 "	<i>Spain</i>	
VE9HX—	49 "	GDS—	43 "	EAQ—	30 "
VE9DR—	49 "	GSA—	49 "	<i>Switzerland</i>	
<i>Costa Rica</i>		GSB—	31 "	HBL—	31 meters
T14NRH—	31 meters	GSC—	31 "	HBP—	38 "
		GSD—	25 "	<i>U. S. S. R.</i>	
<i>Dom. Rep.</i>		GSE—	25 "	RV59—	50 meters
HIZ—	47.5 meter	GSF—	19 "	<i>Venezuela</i>	
HIZ—	20 " phone	GSG—	19 "	YV1BC—	49 meters
				YV3BC—	49 "

U. S. A.

All of the U. S. Stations, including W9XZ (stratosphere balloon) from which I have a verification.

I have heard many more stations, but as yet I haven't received verifications from them.

FRANCIS FEKEL,

Garden Road,

Vineland, N. J.

HKD Barranquilla, Colombia, S. A.
YV3BC Caracas, Venezuela, S. A.
HC2RL Guayaquil, Ecuador, S. A.
GBS Rugby, England
LU5BV Buenos Aires, Arge., S. A.
PHI Huizen, Holland
DIQ Konigs Wusterhausen, Germany
I2RO Rome, Italy
HBP Geneva, Switzerland
HJ1ABB Barranquilla, Colombia, S. A.
P2DQ Porto Alegre, Brazil, So. A.
K4SA Porto Rico (amateur)
HJ2 Bogota, Colombia, S. A.
PLV Malabar, Java, Dutch East Indies
LSN Buenos Aires, Arg. So. A.
LSX Buenos Aires, Arg. So. A.
HJP Bogoto, Colombia, S. A.
VK2ME Sydney, Australia
VK3ME Melbourne, Australia
T14NRH Herida, Costa Ric, aC. A.
QGW Guatemala, C. A.
CMCI Havana, Cuba

I have verifications from most of these, with some slow in answering, so you see the reception in this part of Middle West is very satisfactory.

Yours respectfully,

WALTER E. BYERS,

4524 So. 16th St., Omaha, Neb.

A hint: Keep a small electric clock near your s.w. receiver, and make accurate observations of the time when logging foreign stations.

6:00 p.m. to 8:00 p.m. and they were heard R9+. In the morning they again used GSF for transmission two and sometimes I could not even hear their carrier, yet during the evening they would come through better than GSB. During the summer months reception from DJD at night was better than DJC.

I also find that the South American stations on 20-meter phone come in much better after dark. All these tests were made on a t.r.f. receiver using a 58 r.f., 57 detector, 56 first a.f., a 2A5 power amplifier, and 80 rect. So I guess location has something to do with it.

I have heard and received verifications from the following stations:

Chicago, Illinois

I want to tell you about my reception of EAQ. Do you remember the article "Does the Moon Affect Radio Reception?" Well, I am convinced that it does. About January 30 I heard EAQ, QSA5, R6 and the moon was not quite full. January 31, I heard EAQ again and they came in QSA5, R6-7 and the moon was almost full. All the days up until the moon was full EAQ's strength gradually increased. Then on February 3, when the moon started to get smaller, they only came in QSA4, R4. Of course, these things may only have been coincidences.

Now about my "veries." Since last March 29, I have received cards from HAT, Hungary; GSA, England; GBU, England; GBC, England; VK3ME, Australia; EAQ, Spain; DJB, Germany; KTJY, Byrd Expedition; and K4SA, Puerto Rico.

I would be glad to answer any correspondence concerning the Byrd Expedition.

PHILIP SCHAACK,
5349 Sheridan Road,
Chicago, Ill.

New Frequencies for Police Radio

THE Federal Radio Commission has adopted a new allocation plan for state and municipal police frequencies, effective May 1, 1934, in keeping with revised rules and regulations recommended by the Engineering Division, which provide for additional police channels made available at the Mexico City Conference.

The plan adopted requires adjustment of the present frequency assignments to police stations and allows for future assignments to municipalities or states requesting police radio facilities. It should provide for better operating conditions in the municipal police service, since, in general, the size of the zones required to share the use of a single frequency is materially reduced and the average separating between zones required to share the same frequency is increased.

Since previous to this plan state police stations were allocated only three frequencies, a very great improvement should be expected inasmuch as nine frequencies are now available, and since the plan provides for an orderly growth of this

service as additional states install radio equipment.

The use and development of radio as an aid in preventing crime and in the apprehension of criminals is an important step in human progress. This phase of radio has been given much thought and study by the Commission and it is highly gratified at the results accomplished and the future outlook of the police radio service.

Nearly five years ago the Commission saw the potentialities of radio as an aid to police systems, and at that time allocated three frequencies for that purpose. Soon after that action by the Commission some municipalities began experimenting with police frequencies and the results accomplished electrified police officials throughout the country.

The progress and expansion of radio police systems since then represents one of the real dramas of radio. So successful were the operation in the early days, that the Commission three years ago assigned nine frequencies for police use, one year ago that number was increased to 11, and under the new plan 20

channels are immediately available for state and municipal radio systems in the United States.

There are now 128 municipalities and 8 states equipped with their own radio police communication systems. More than 4,000 police cars are equipped with receiving sets, and, judging by the success of recent experiments, it is conceivable that all of them will eventually be equipped with transmitting sets permitting two-way communication.

Reports filed at intervals with the Commission regarding the activities of, and the results accomplished by, the police radio services, prove conclusively they are rendering a distinct public service in protecting individuals and communities from offenders of organized society.

There are no "air pirates" operating in this band. Every police radio communication system in the United States is licensed by the Federal Radio Commission. The Commission has constantly encouraged the use of radio by the police and it has assisted in the development of police radio systems by rendering technical advice and coun-

List of International Call Assignments

The international call letter assignments underwent some extensive changes early this year, when the acts of the Madrid Radio Convention of 1932 went into effect. For the most part the changes affect the smaller countries, but one really important shift gives all the R and U calls to the Union of the Socialist Soviet Republics, ("Russia"). The list as given below incorporates the official changes.

Block of Calls	Country	Amateur Prefix	Block of Calls	Country	Amateur Prefix
CAA-CEZ	Chile	CE	VHA-VMZ	Australia	VK
CFA-CKZ	Canada	VE	VOA-VOZ	Newfoundland	VO
CLA-CMZ	Cuba	CM	VPA-VSZ	British colonies and protectorates	
CNA-CNZ	Morocco	CN		British Guiana	VP
COA-COZ	Cuba	CN		Fiji, Ellice Ids., Zanzibar	VP1
CPA-CPZ	Bolivia	CP		Bahamas, Barbados,	
CQA-CRZ	Portuguese colonies:			Jamaica	VP2
	Cape Verde Ids.	CR4		Bermuda	VP9
	Portuguese Guinea	CR5		Fanning Id.	VQ1
	Angola	CR6		Northern Rhodesia	VQ2
	Mozambique	CR7		Tanganyika	VQ3
	Portuguese India	CR8		Kenya Colony	VQ4
	Macao	CR9		Uganda	VQ5
	Timor	CR10		Malaya (including Straits Settlements)	VS1-2-3
CSA-CUZ	Portugal:			Hongkong	VS6
	Portugal proper	CT1		Ceylon	VS7
	Azores	CT2	VTA-VWZ	British India	VU
	Madeira	CT3	VXA-VYZ	Canada	
CVA-CXZ	Uruguay	CX	W	United States of America:	
CYA-CZZ	Canada			Continental United States	W
D	Germany	D		Philippine Ids.	KA
EAA-EHZ	Spain	EAR		Porto Rico and Virgin Ids.	K4
EIA-EIZ	Irish Free State	EI		Territory of Hawaii	K6
EIA-ELZ	Liberia	EL		Territory of Alaska	K7
EPA-EQZ	Persia			United States of America:	W
ESA-ESZ	Estonia	ES		Peru	OA
ETA-ETZ	Ethiopia (Abyssinia)	ET		OEA-OEZ	
EZA-EZZ	Sarre Territory			Austria	OH
F	France (including colonies):			Finland	OI
	France proper	F		Czechoslovakia	OK
	French Indo-China	F1		Belgium and colonies	ON
	Tunis	FM4		Denmark	OZ
	Algeria	FM8		The Netherlands	PA
G	United Kingdom:			Curacao	PJ
	Great Britain except Ireland	G		Dutch East Indies	PK
	Northern Ireland	GI		Brazil	PY
HAA-HAZ	Hungary	HA		Surinam	PZ
HBA-HBZ	Switzerland	HB		Union of the Socialist Soviet Republics	R
HCA-HCZ	Ecuador	HC	SAA-SMZ	Sweden	SM
			SOA-SRZ	Poland	SP
			SFA-SUZ	Egypt:	
				Sudan	ST
				Egypt proper	SU
				Greece	SV
			SVA-SZZ	Turkey	TA
			TAA-TCZ	Iceland	TF
			TFA-TFZ	Guatemala	TG
			TGA-TGZ	Costa Rica	TI
			TIA-TIZ	France and Colonies and Protectorates	
			TKA-TZZ	U.S.S.R.	U
			U	U.S.S.R.	U
			VAA-VGZ	Canada	VE
				British colonies and protectorates	
				Transjordan	ZC1
				Palestine	ZC6
				Nigeria	ZD
				Southern Rhodesia	ZE1
			ZKA-ZMZ	New Zealand:	
				Cook Ids.	ZK
				New Zealand proper	ZL
				British Samoa	ZM
			ZPA-ZPZ	Paraguay	ZP
					ZS
			ZSA-ZUZ	Union of South Africa	ZT
					ZU

sel. Also the Inspectors in Charge of the field service, located in 20 important cities, have been available to the police for consultation.

The heartiest cooperation has always prevailed between the police departments of the various states and municipalities and the Commission regarding the radio police services. The law enforcement authorities have expressed keen appreciation over the attitude of the Commission and its liberal policy.

In connection with this plan, a study has been made of the power that should be allocated to police stations. Inasmuch as the conditions under which municipal police stations operate are not to be changed materially, no change in the rules and regulations were made. There is no rule at the present moment specifying the maximum power that may be installed at state police stations. It was, therefore, decided that as a matter of policy the maximum power be limited to 5 kw. day, 1 kw. night, and that the states be encouraged to install a number of transmitters of less power rather than one or two transmitters of maximum power.

In addition to stations licensed for police service in the conventional medium — high frequency band—there are outstanding at this time experimental authorizations which permit 50 municipalities to operate 125 stations in the ultra-high frequency range, in the neighborhood of Prueters.

Mr. Herbert L. Pettey, secretary of the Federal Radio Commission, has prepared a complete list of the police frequencies especially for SHORT WAVE RADIO. This is published herewith for the information of all short-wave listeners. The list is arranged alphabetically by names of cities and is very easy to follow. The frequencies are given in kilocycles. The notation "n-c" means no change. "For. Freq." means former frequency, "Freq. EFF. M. 1 1934" means frequency effective May 1, 1934.

The list is arranged alphabetically according to the names of the cities. Readers who want to look up stations according to their call letters are referred to pages 12, 13, 14, 15 and 16 of the April, 1934, issue of SHORT WAVE RADIO, copies of which are obtainable at the regular price.

Megacycle Readings on New All-Wave Receivers

THE dials of many of the new all-wave receivers are marked directly in megacycles instead of kilocycles or the usual 0-100 graduations. This is done to give the inexperienced operator at least a rough idea where to expect foreign and domestic stations.

The scale readings are given in megacycles (abbreviated mc.) rather than kilocycles (kc.) because the kilocycle figures occupy too much space. If you merely remember that one kilocycle is one thousand cycles, and one megacycle is a million cycles, you will have no trouble converting one to the other. For instance, 6000 kilocycles is the same as 6 megacycles; 13,000 kilocycles, 13 megacycles. Moving the decimal point three places back or forth gives either kc. or mc.

It must be remembered that the dial calibrations of four- and five-range all-wave receivers are only approximate, and are intended only as a guide.

Call Letters	Location	Freq.	
		For. Freq.	Eff. M. 1 1934
KGZV	Aberdeen, Wash.	2414	N/C
WPDO	Akron, Ohio	2458	N/C
WPGH	Albany, N. Y.	2414	N/C
KGZX	Albuquerque, N. M.	2414	N/C
WPED	Arlington, Mass.	1712	N/C
WPDY	Atlanta, Ga.	2414	N/C
WPDN	Auburn, N. Y.	2458	2382
KGPS	Bakersfield, Cal.	2414	N/C
WPFH	Baltimore, Md.	2414	N/C
WPCA	Bay City, Mich.	2442	2466
KGJF	Beaumont, Tex.	1712	N/C
WPFK	Hackensack, N. J.	2430	N/C
KSW	Berkeley, Cal.	1658	N/C
WPGI	Binghamton, N. Y.	2442	N/C
WPFM	Birmingham, Ala.	2414	2382
WMJ	Buffalo, N. Y.	2422	N/C
KGZG	Cedar Rapids, Ia.	2470	2466
KGZF	Chanute, Kans.	2450	N/C
WPDV	Charlotte, N. C.	2458	N/C
WADB	Chicago, Ill.	1712	N/C
WADC	Chicago, Ill.	1712	N/C
WADD	Chicago, Ill.	1712	N/C
WKDU	Cincinnati, O.	1712	1706
WPFJ	Clarksburg, W. Va.	2414	2490
WRBH	Cleveland, O.	2458	N/C
KGZP	Coffeyville, Kans.	2450	N/C
WPFJ	Columbus, Ga.	2414	N/C
WPGK	Cranston, R. I.	2470	2466
KVP	Dallas, Tex.	1712	N/C
KGPN	Davenport, Ia.	2470	2466
WPDN	Dayton, Ohio	2430	N/C
KGXV	Denver, Colo.	2442	N/C
WCK	Belle Isle (Det.) Mich.	2414	N/C
WPDZ	Detroit, Mich.	2414	N/C
KGZG	Des Moines, Ia.	2470	2466
WPDW	Washington, D. C.	2422	N/C
WPEI	E. Providence, R. I.	1712	N/C
KGZM	El Paso, Tex.	2414	N/C
WPDF	Flint, Mich.	2442	2466
WPDZ	Ft. Wayne, Ind.	2470	2490
WPDJ	Columbus, Ohio	2430	N/C
KGZA	Fresno, Cal.	2414	N/C
WPEB	Grand Rapids, Mich.	2442	N/C
WRDR	Grosse Point, Mich.	2414	N/C
WMO	Highland Park, Mich.	2414	N/C
KGJQ	Honolulu, T. H.	2450	N/C
WPGO	Huntington, N. Y.	2414	2490
WMDZ	Indianapolis, Ind.	2442	N/C
WPFJ	Jacksonville, Fla.	2442	N/C
KGPE	Kansas City, Mo.	2422	N/C
KGZH	Klamath Falls, Ore.	2442	2382
WPFO	Knoxville, Tenn.	2470	2474
WPDZ	Kokomo, Ind.	2470	2490
WPDJ	Lansing, Mich.	2442	N/C
KGHC	Las Vegas, Nev.	2470	2474
WPET	Lexington, Ky.	1712	1706
KGZU	Lincoln, Neb.	2470	2490
KGHZ	Little Rock, Ark.	2430	2406

Call Letters	Location	Freq.	
		For. Freq.	Eff. M. 1 1934
KGPL	Los Angeles, Cal.	1712	N/C
WPDE	Louisville, Ky.	2442	N/C
KGZV	Lubbock, Tex.	2458	N/C
WPEC	Memphis, Tenn.	2470	2466
WPFJ	Miami, Fla.	2442	N/C
WPDK	Milwaukee, Wis.	2450	N/C
KGJF	Minneapolis, Minn.	2430	N/C
WPGP	Muncie, Ind.	2442	N/C
WPFJ	Muskegon, Mich.	2442	N/C
WPGS	Mineola, N. Y.	2414	2490
WPFN	Fairhaven, Mass.	1712	N/C
WPEK	New Orleans, La.	2430	N/C
WPFJ	Newton, Mass.	1712	N/C
WPEE	Brooklyn, N. Y.	2450	N/C
WPEF	New York, N. Y.	2450	N/C
WPEG	New York, N. Y.	2450	N/C
KGPH	Oklahoma City, Okla.	2450	N/C
KGPI	Omaha, Neb.	2470	2466
WPFJ	Palm Beach, Fla.	2442	N/C
KGJK	Palo Alto, Calif.	1674	N/C
KGJX	Pasadena, Calif.	1712	N/C
WPFV	Pawtucket, R. I.	2470	2466
WPDF	Philadelphia, Pa.	2470	2474
KGZJ	Phoenix, Ariz.	2430	N/C
WPDZ	Pittsburgh, Pa.	1712	N/C
WPGJ	Port Huron, Mich.	2414	2466
WPFJ	Portland, Me.	2422	N/C
WPGF	Providence, R. I.	1712	N/C
KGPP	Portland, Ore.	2442	N/C
WPGI	Portsmouth, Ohio	2430	N/C
WPDH	Richmond, Ind.	2442	N/C
WPFJ	Reading, Pa.	2442	N/C
WPDZ	Rochester, N. Y.	2458	2422
WPGD	Rockford, Ill.	2458	N/C
WPEJ	Saginaw, Mich.	2442	N/C
KGPC	St. Louis, Mo.	1712	1706
WPDZ	St. Paul, Minn.	2430	N/C
WGZR	Salem, Ore.	2442	N/C
KGJW	Salt Lake City, Utah	2470	2406
KGZO	Santa Barbara, Cal.	2414	N/C
KGZT	Santa Cruz, Cal.	1674	N/C
KGZV	San Bernardino, Cal.	1712	N/C
KGZD	San Diego, Cal.	2430	2490
KGPD	San Francisco, Cal.	2470	2466
KGPM	San Jose, Cal.	2470	1674
KGPF	Santa Fe, N. Mex.	2414	N/C
KGPA	Seattle, Wash.	2414	N/C
KGPK	Sioux City, Ia.	2470	2466
WPEH	Somerville, Mass.	1712	N/C
WPGN	South Bend, Ind.	2470	2490
KGHS	Spokane, Wash.	2414	N/C
WPFJ	Swarthmore, Pa.	2470	2474
WPEA	Syracuse, N. Y.	2458	2382
KGZN	Tacoma, Wash.	2414	N/C
WRDQ	Toledo, Ohio	2470	2474
KGZC	Topeka, Kans.	2422	N/C
WPDA	Tulare, Cal.	2414	N/C
KGPO	Tulsa, Okla.	2450	N/C

Call Letters	Location	Freq.	
		For. Freq.	Eff. M. 1 1934
WPGJ	Utica, N. Y.	2414	N/C
KGJG	Vallejo, Cal.	2422	N/C
KGZQ	Waco, Tex.	1712	N/C
KGZI	Wichita Falls, Tex.	1712	2458
KGZJ	Wichita, Kans.	2450	N/C
WPEM	Woonsocket, R. I.	2470	2466
WPDG	Youngstown, Ohio	2458	N/C

CONSTRUCTION PERMITS ISSUED FOR MUNICIPAL POLICE STATIONS

KGHU	Austin, Tex.	2382	N/C
WPFJ	Asheville, N. C.	2474	N/C
KGHN	Hutchinson, Kansas	2450	N/C
WPGM	La Grange, Ga.	2414	N/C
KGHP	Lawton, Okla.	2466	N/C
KGJH	Long Beach, Cal.	2430	2490
KGPR	Minneapolis, Minn.	2430	N/C
WPGW	Mobile, Ala.	2382	N/C
WPGT	New Castle, Pa.	2482	N/C
KGHX	Santa Ana, Cal.	2430	2490
KGHM	Reno, Nev.	2442	2474
WPEJ	Shreveport, La.	2430	N/C
KGHV	Corpus Christi, Tex.	2382	N/C
KGJY	Whittier, Cal.	1712	N/C
WPGV	Boston, Mass.	1712	N/C
WPGU	Cohasset, Mass.	1712	N/C

LICENSED STATE POLICE STATIONS

KGHO	Des Moines, Ia.	1534	1682
WMP	Framingham, Mass.	1574	1666
WPEL	Middleboro, Mass.	1574	1666
WPEW	Northampton, Mass.	1574	1666
WPEV	Portable, Mass.	1574	1666
WRDS	E. Lansing, Mich.	1574	1666
WPGC	S. Schenectady, N. Y.	1534	1658
WPGG	Findlay, Ohio	1682	N/C
WBA	Harrisburg, Pa.	190	N/C
WBR	Butler, Pa.	190	N/C
WDX	Wyoming, Pa.	190	N/C
WJL	Greenburg, Pa.	190	N/C
WMB	W. Reading, Pa.	190	N/C
KGZE	San Antonio, Tex.	2506	1658
KGHA	Highway Portable & Mobile, Seattle, Wash.	2506	2490
KGHB			
KGHC			
KGHD			

CONSTRUCTION PERMITS FOR STATE POLICE STATIONS

WPGQ	Columbus, O.	1682	N/C
KGHE	Snoqualmie Pass, Wash.	2506	2490
KGHQ	Chinook Pass, Wash.	2490	N/C
KGHR	Mobile	2490	N/C

•• S. W. Receiver Review ••

To assist prospective purchasers of short-wave receivers in selecting equipment most suitable for their own needs, we have established this regular monthly department, in which factory-built sets will be described honestly, accurately, and completely after having been tested thoroughly by us. Readers are invited to suggest particular sets in which they are interested, and we will endeavor to obtain stock samples for test and write-up. Please do not ask us to make comparisons between different receivers.

MAKE: Zenith Model 288; manufacturer, Zenith Radio Corp.

MECHANICAL DETAILS: Overall length, 15 $\frac{3}{4}$ ", depth 10 $\frac{1}{2}$ ", height 18 $\frac{1}{2}$ ".

REQUIRED ACCESSORIES: This receiver is sold complete with tubes, speaker and cabinet.

PRICE: Complete with tubes, speaker and cabinet, \$75.00 (list).

TYPE OF SET: This receiver is an eight-tube superheterodyne of the selector switch type which covers the range from 565 to 12 meters. It is equipped with tone, volume and sensitivity controls, antenna trimmer for the short-wave bands, rotating mask dial, and automatic volume control.

The selector switch and the tuning dial are divided into five distinct bands, four for short-wave use and one for the standard broadcast band. The four bands for short-wave reception are divided as follows: 1.45 to 3.4 megacycles, 3.2 to 6.9 megacycles, 6 to 12 megacycles, and 11.5 to 25 megacycles. The regular broadcast band covers the range from .54 to .156 megacycles.

GENERAL DESCRIPTION: The eight tubes in this receiver are used in the following manner: a 58 tuned r.f.

The Zenith Model 288 All-Wave Receiver

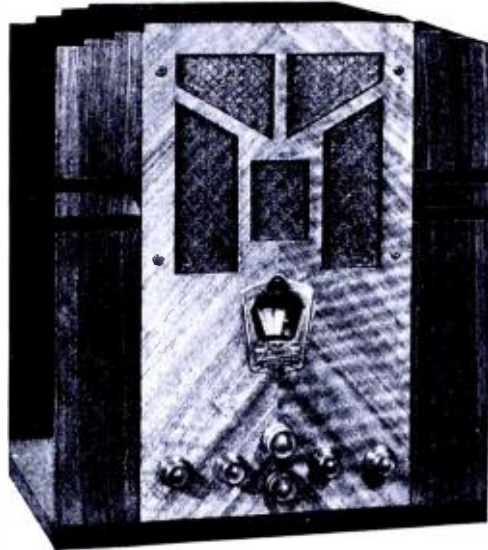

Front view of the receiver.

stage, a 58 first detector, a 56 oscillator, two 58's in the i.f. amplifier, a 2A6 as the second detector, and a 59 connected as a pentode in the output stage. Looking at the front of the panel, the left knob is the tone control, that immediately to the right is the volume control and off-on switch, the lower center knob is the

sensitivity control and phonograph switch, the upper center knob is the station selector, the knob second from the right is the band selector switch, and that to the extreme right is the short-wave trimmer condenser.

The dial itself is very readable and divided into five concentric bands, each band graduated directly in megacycles. As the selector switch is rotated from one position to another, the band in use automatically illuminates. In this manner, no confusion arises as to which band is being listened to. The calibration of the particular receiver operated by your reviewer was as accurate as could be expected in a commercial set.

CIRCUIT DETAILS: Reference to the schematic circuit will show several interesting details of the circuit used in this receiver. Of these details, perhaps the selector switch is of greatest importance. As the selector switch is turned to the short-wave bands, the tuning inductances are paralleled. This same procedure is also followed for the oscillator coils. This method is distinct from the more usual one of having a separate and distinct coil for each of the short-wave bands. The efficiency, however, is about the same, and, as

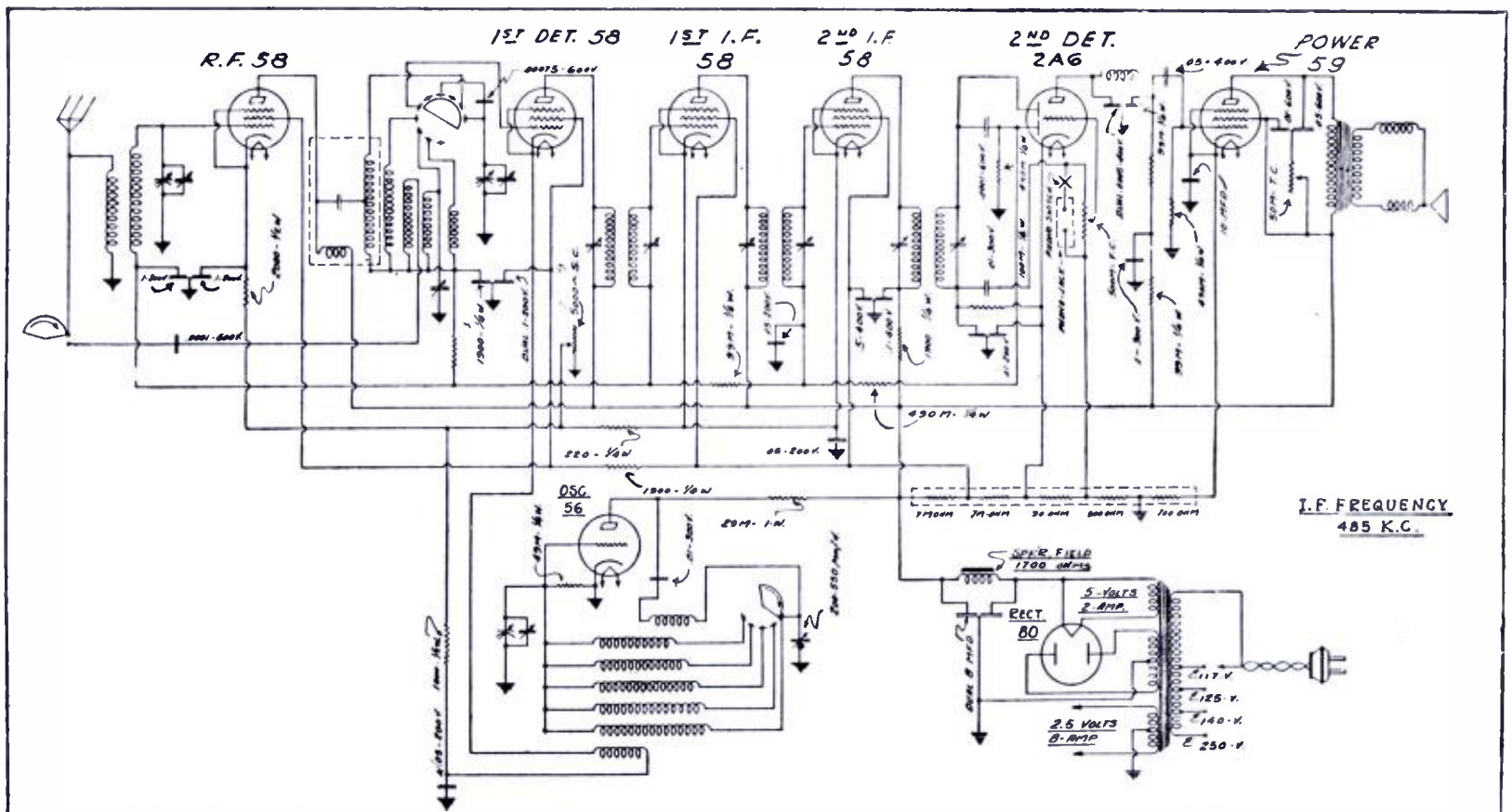

Complete schematic wiring diagram of the Zenith Model 288 All-Wave Receiver.

far as operation is concerned, there is very little difference between the two methods. Another interesting feature of the rotary switching system is the fact that, on all but the broadcast bands, the large tuning condensers are connected in series with a .00075 mf. fixed condenser. This has the effect of tuning with a smaller condenser, exactly as would be done in a strictly short-wave set.

Both a sensitivity and a volume control are employed in this receiver. The sensitivity control varies the bias on the first r.f. and on the two i.f. tubes, while the volume control is connected in the diode circuit of the second detector in the normal fashion. Shunted directly across this volume control are the phone switch and the tip-jacks to the phonograph pick-up.

Your reviewer considers these separate controls a distinct improvement over the use of a single volume control. For one thing, it permits control of volume of the phonograph in the audio amplifier and may be adjusted to prevent overloading the triode section of the 2A6 or the 59 regardless of the setting of the sensitivity control when the radio set is being used. Thus, the volume control may be set just below the point of overload, and the sensitivity control used to vary the volume of incoming signals.

A tone control connected across the primary of the output transformer is advantageous when background noise in short-wave reception is to be eliminated.

In view of the fact that this all-wave receiver has four bands for short-wave use, tuning is not difficult. In fact, tuning in a foreign station with this receiver is about as simple as with any strictly short-wave set not equipped with band-spread tuning. This does not mean that stations can be tuned in by the mere twirl of a dial. The same care and patience must be exercised as would be in any other set.

Another very useful feature is the short-wave trimmer condenser. This unit lines up the various tuned stations very accurately so as to secure maximum sensitivity in the i.f. stages, which, incidentally, are tuned to 485 kilocycles.

Stations in the 49-meter band were easily separated without noticeable interference. The automatic volume control works very well, al-

though, in the opinion of your reviewer, it would be desirable to amplify it a little.

Your reviewer also noticed some image-frequency response. Stations could be tuned in on two points on the dial separated by twice the i.f. The response of the station, however, on one of the bands was extremely weak compared with the other. This, perhaps, may be accounted for to some extent by the fact that part of the signal from the antenna feeds into a separate primary interposed between the first detector tuning inductances.

ANTENNA: The receiver is designed for use with the ordinary broadcast antenna, although, of course, if more than average short-wave results are desired, then it is absolutely essential that the usual precautions regarding good short-wave antenna installations be observed.

OPERATION AND PRECAUTIONS: The operation of the receiver is extremely simple. The antenna and ground are connected, the line cord is plugged into the receptacle and the set turned on. The sensitivity control is set at maximum and the volume control about half-way up. Signals should come in on both the short-wave and broadcast bands with much more than usual volume. About a half-hour of careful manipulation is usually sufficient to acquaint the operator with the limits of use of the various knobs, which, incidentally, are unmarked on the panel for appearance, not for confusion!—*L. M.*

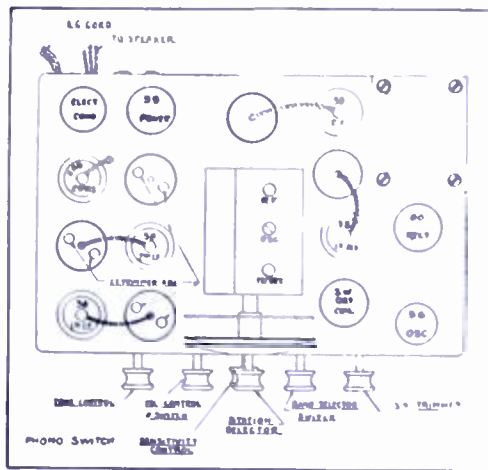

Plan view of the receiver chassis, showing the arrangement of the main parts.

Radio Code Proves Easy for S. W. Fans

THAT short-wave broadcast listeners without any previous knowledge whatsoever of the subject can master the radio code in a short time if they are given the proper instruction is amply proved by the experience of the Short Wave Club of New York. At one of the January meetings of the club, the members expressed an interest in the code as a means of increasing the enjoyment they can obtain from their short-wave receivers, and they were quite enthusiastic when the chairman of the meeting, who happens to be the editor of *SHORT WAVE RADIO*, volunteered to hold a code class for an hour before the formal opening of each meeting. In three weeks almost fifty people who started from scratch were up to five or eight words a minute, and some were already beginning to ask for more speed!

The method of instruction that proved so successful was described at length on page 15 of the May, 1934, issue. It is very simple and can be followed without trouble by any person who possesses the small amount of patience necessary for tuning a short-wave receiver.

A number of questions popped up at the club classes that probably will

be asked by other interested people.

First, it should be emphasized that all dit-dah combinations must be copied immediately as the letters they represent. For instance, if you hear dah-dit-dah-dit, write down C, NOT -- --; if the transmission is too fast for you to transcribe, tune for a slower-sending station.

Beginners invariably try to send faster than they can receive. This is a bad habit to get into. The best way to overcome it is to have some friend practice with you. If you speed up too much, he'll speed up too, and then neither of you will be able to copy the other's sending!

There is a long list of international abbreviations, called "Q" signals, used by radio operators everywhere. This is too long to be published here, but can be found in "The Radio Amateur's Call Book," which is the only book of its kind now available. (The government no longer publishes an amateur call list). The "Q" signals also appear in the "Radio Amateur's Handbook." Both of these books, are valuable to any short-wave fan.

The "Q" signals enable operators of different nationalities to conduct business over the air and to carry

on almost complete conversations, even though they know nothing about each other's language. For instance, an American operator communicating with a Japanese operator can send the single signal "QRK?" which means, "Do you receive me well? Are my signals good?" The Japanese does not answer "yes" or "no," because "yes" or "no" sent in Japanese would be unintelligible to the American. He simply sends back "QRK," which means, "I receive you well. Your signals are good." Or, perhaps, "QRJ," which means, "I cannot receive you. Your signals are too weak." Of course, each operator has a copy of the "Q" list in his own language.

There are also many unofficial abbreviations that are widely used by amateur and commercial operators. "That" becomes "tt"; "old man," "om"; "traffic," "tfc"; "message," "msg"; "again," "agn"; "see you later," "cul."

Operators of amateur phone transmitters sometimes use the telegraphic abbreviations during their conversations, although there is no particular sense to this practice.

The number "73," that terminates practically all amateur contacts, means "best regards."

Selecting an S. W. Receiver

WITH the public interest in short-wave reception increasing by leaps and bounds, many individuals have been confronted with the problem of selecting receivers either for themselves or for friends and relatives who look to them for radio advice. Many people are confused by conflicting claims of competitive manufacturers and are inclined to think that some of the wonderful reports of foreign reception they read about are somewhat exaggerated. To assist its readers in choosing sets for themselves and for others, the staff of SHORT WAVE RADIO has looked over the market and is presenting herewith a sort of review of available apparatus.

First of all, it must be understood that radio merchandise is no different from any other kind of merchandise, and that the relative prices of two similar items give a pretty good indication of their relative merits. This is why it is impossible for us or anyone else to make comparisons between two apparently similar sets having a price ratio of two to one or three to one. Two receivers may use identical circuits and tube combinations, yet their general construction, the quality of their parts, and the overall workmanship can readily account for the fact that one set sells for \$75.00 and the other for \$150.00

One to Nineteen Tubes

There are now on the market short-wave receivers using anywhere from one to nineteen tubes. A simple and inexpensive receiver that will give excellent results if carefully operated can be purchased in a kit form for as little as \$3.00. This does not include batteries and earphones, which will increase the overall cost to about \$5.00. This set is a fundamental regenerative receiver. While the signals it produces are weak and can be heard only with earphones, sets of this type actually bring in foreign stations. They are excellent for boys and girls, and, for that matter, also for their fathers. One-tube sets are critical, must be tuned carefully, and frequently suffer from hand-capacity effects. Considering the number of stations they will bring in, they certainly are well worth their cost.

There is a whole flock of simple two- and three-tube sets, most of them for battery operation and a few for a. c. operation. If they use metal chassis, they do not have hand-capacity effects and are, therefore, fairly easy to tune. The two-tube outfits are still in the earphone class, while most three-tube sets will operate small magnetic loudspeakers on some of the more powerful short-wave stations. Sets of

Some Practical and Unbiased Advice on the Different Simple and Advanced Sets of the T.R.F. and Superheterodyne Types Now on the Market

this type represent an investment of between \$11.00 and \$15.00. They are all still of the regenerative type, some with an untuned r.f. stage ahead of the detector or with two audio stages. Some models are available with neat little metal cabinets. These sets usually require three 45-volt B batteries and a source of filament current which may be either a bank or ordinary No. 6 dry cells or one of the special non-rechargeable batteries made especially for the purpose.

Practically all the a. c. models have separate little power packs. There is at least one receiver in this general price class which operates on 110 volts, either a. c. or d. c. The three-tube a. c. sets are more likely to give satisfactory loudspeaker operation than most of the battery models, for the simple reason that practically unlimited power is available from the a. c. line and the tubes can, therefore, be operated at maximum output.

Really satisfactory loudspeaker operation of foreign stations becomes practicable with some of the higher priced three-tube battery or a. c. receivers, and certainly with the four-tube models. In the four-tube class there is the regenerative detector followed by two stages of audio amplification and preceded by either an untuned r.f. stage or a tuned r.f. stage. The sets employing the tuned r.f. stage require two plug-in coils for each wave range, and are more sensitive and selective than the untuned r.f. outfits. The necessity for the extra coils, of course, increases the price of the tuned r.f. sets. Receivers of this type cost approximately \$25.00 to \$35.00, some of the better grades even running up to \$50.00.

The Loudspeaker

With the three- and four-tube sets, a magnetic speaker or a small dynamic can be used. The magnetic requires no field supply and is simply connected like a pair of phones. The usual dynamic speakers require field current, which, in some cases, can be obtained from the power pack of the a. c. receiver. Probably the most convenient type of dynamic speaker is the kind that has a permanent field magnet. This requires no separate field excitation and is merely hooked to the output posts

of the receiver like a magnetic speaker.

It is wise for the prospective purchaser of a short-wave receiver to inquire carefully about loudspeaker provisions. Some excellent little receivers, with plenty of volume for dynamic speaker operation, have provision only for magnetics. If a dynamic speaker is desired, it must contain its own field supply unit. A speaker of this kind is likely to cost as much as \$10.00.

Practically all of the aforementioned short-wave receivers using from one to four tubes may be obtained in either kit or completely wired form. The assembly work is easy and will furnish the constructor with considerable enjoyment. Anyone who can use a screw driver, a pair of pliers, and a soldering iron will have no trouble in following instructions, even though he never built a set before. Practically all of these sets use plug-in coils and cover a tuning range from about fourteen meters up to two hundred meters (the bottom of the broadcast band) usually with four coils or four pairs of coils. For the person who wants to enjoy the thrills of short-wave reception without making any considerable initial investment, small regenerative receivers are really quite good. Thousands of such sets are in use.

Superhet Features

The second and more advanced type of short-wave receiver is the superheterodyne. In past years, the super was regarded as too complicated in construction and operation for most radio enthusiasts, but recent advances in tube and circuit design have changed the situation altogether. As a matter of fact, many of the one-dial superhets now on the market are easier and simpler to operate than the apparently simpler regenerative receivers. The big advantages of the super are its high sensitivity and selectivity. The selectivity in particular is an important feature in view of the crowded condition of the short-wave broadcast channels. Stations that are pretty hopelessly confused in a regenerative tuner can be separated quite sharply by a good superhet. The high gain or amplification of the super makes the use of automatic volume control system practicable, and thus annoying fading effects can be overcome to a large extent.

A number of very fine specialized short-wave superheterodynes are on the market. These range in price from about \$50.00 up to \$200.00. The number of tubes varies from five to nineteen. Some have band spreading, which is a very desirable feature. Plug-in

coils for wave changing continue in favor, but wave-changing switches are rapidly becoming more popular. Considerable prejudice against the use of wave-changing switches seems to exist among the more experienced short-wave fans, but there is no longer any reason for this. True enough, many of the early wave-changing switches were pretty poor mechanisms, but the units now on the market work very smoothly and effectively and have a few of the limitations of their predecessors. Unquestionably, a wave-changing switch is more convenient than a box full of removable plug-in coils. Of course, there are good wave-changing switches and bad ones, just as there are good and bad plug-in coils. Some people have the idea that any plug-in coil is better than the best wave-changing switch, but this is not so at all. The great success achieved by some of the newer short-wave supers containing wave-changing switches must be regarded as significant.

The All-Wave Sets

The superhet field can be subdivided into two further classifications: (1) the straight short-wave set, which covers the 200 to 500 meter broadcast band only incidentally, if at all, and which may use either plug-in coils or a wave-changing switch; and (2) the new all-wave type of set which invariably has a wave-changing switch and which covers not only the short-wave and broadcast bands, but may also even cover the long-wave channels up to 2000 meters. The all-wave sets include a loudspeaker and are housed in attractive cabinets, two points that are certainly in their favor. An enormous amount of engineering work has been done on all-wave circuits by some of the large radio manufacturers, and this is reflected in the highly advanced nature of the latest models. No longer is the all-wave set merely a broadcast receiver with a couple of short-wave coils thrown in at the last moment. In fact, the advent of popularized short-wave reception has brought about some very definite changes in superhet technique, and the short-wave fan is benefiting from them directly.

Replacement Receivers

An all-wave receiver of reputable make should be considered by people who now own old broadcast receivers that have outlived their usefulness. In many cases, it is almost as cheap to buy a whole new all-wave set than to recondition an old receiver. The better all-wave sets not only provide superlative short-wave reception, but also the highest quality of regular broadcast reception. Of course, if the family insists on listening to broadcast programs just when you feel like fishing for Europe or South

America, the only answer is to buy two sets!

The choice of a receiver of the superhet type is not an easy undertaking, as there are so many really good sets of this kind on the market. It is a good idea to collect all the literature that the manufacturers send out for the asking, and also to visit radio stores where the sets are on display. One set may have certain little features that appeal to you, and, therefore, that set is more desirable to you than another. This sounds like pretty obvious advice, but we are asked so many impossible questions along this line that we must use very plain language. Again we must emphasize the importance of price. Do not expect the features of a \$100.00 set in a \$50.00 instrument. Also consider the name and reputation of the manufacturer and study the guarantee, if any. Do not judge a receiver by its external appearance alone. Look in the back of the cabinet and examine the chassis. The difference between good and bad workmanship is quickly evident even to an untrained observer.

A good proportion of the people who are now getting into the short-wave "game" are former set build-

ers of the 1921-1926 broadcast era. They have been re-bitten by the "DX" bug and want to try their hand again at dial twirling. If you are one of these people, or if you are approached for friendly advice by one, our suggestion is that you consider a tuned rf.-regenerative receiver or a superhetrodyne, depending on how much you are able to spend. You probably will find the simpler sets too simple. If you still have your tools and feel the constructional urge, buy the set in kit form; you'll probably have a lot of fun. If you don't want to bother with this sort of thing any more, the completely assembled and wired sets, which cost only a little more than the kits, will satisfy you nicely.

If you want a single receiver for the entertainment of the entire family, and want the most results per dollar of investment, you certainly can do no better than to select an all-wave set. In looking over the available sets of this type, pay particular attention to the tuning dial. The tuning on the short-wave bands of these sets is extremely sharp, and unless the dial has a respectably large reduction drive and turns very smoothly you will miss many stations.—R. H.

New Aircraft Radio Rules

THE Federal Radio Commission has amended its rules and regulations regarding aeronautical radio service so as to permit the handling of general public message correspondence between aircraft and aeronautical ground stations.

The new regulations, applicable to all transport air lines, are designed to promote safety, and at the same time permit passengers in aircraft to send and receive private radio telegrams.

In the handling of messages for the public, priority must be given to safety messages. To this end, the equipment to be used and the operators' listening watches must be such as to permit the immediate interruption of public service messages whenever it is necessary to send or receive emergency traffic.

The Radio Act of 1927 placed upon the Federal Radio Commission the duty of granting radio station licenses, so that the public as a whole may receive the greatest benefit. Heretofore, when granting licenses, the Commission, under its rules and regulations, has specifically prohibited the acceptance of general public message traffic between aircraft and ground stations. This was necessary because it was believed that during the period of development of an efficient aviation radio-communication system the public as a whole would receive the greatest benefit if the service was restricted to the transmission and reception of emergency messages, including meteorological data, which is so vital to the safety of life and property in the air.

It is now recognized that radio communication between aircraft and ground has been adequately perfected to permit the handling of general public message service without affecting the safety of aircraft in flight. By maintaining separate operator's watches, and using separate frequencies, it is possible for the ground stations to send and receive at the same time. In the case of aircraft, it is possible to receive two messages simultaneously, and if it is desired to send an emergency message to an aircraft at the time the aircraft is sending a public service message it is also possible to interrupt the public service message in order to clear the emergency message.

The following are the important features of the aviation rules with respect to aircraft and aeronautical ground stations to be licensed for the handling of general public message correspondence:

1. The prompt and efficient handling of emergency messages involving safety of life and property in the air is of paramount importance. In order to insure against delay or interference to emergency traffic when handling messages for the public, applicants desiring licenses for aviation public service are required to install certain duplicate equipment, maintain separate operators' watches, and comply with other miscellaneous rules which are designed to promote safety.

2. Public service messages will be handled by continuous wave teleg-

(Continued on page 41)

Tuning the Antenna Circuit

SUMMARY: Why don't more simple sets tune the antenna system? It certainly is an economical way of getting more signal per tube. The reason seems to be that people simply do not think of it, although tuned antenna systems are as old as radio itself.

This article tells you how to change over your present system to enable it to be tuned. The advantages and the comparatively unimportant disadvantages are outlined. Let's get busy and make the change now.

THE cyclic recurrence of radio circuits is becoming more and more evident in the short-wave field as the days go by. Some ten years or so ago, practically every receiver had its antenna circuit tuned so that maximum energy was transferred from the antenna proper to the first tube. Then, with the advent of single-control receivers which did not permit antenna tuning, it went into discard. Furthermore, highly sensitive circuits and the low cost of tubes accelerated the passing of resonant antenna systems.

The Resonant Aerial

Now that the ultra high frequencies between 1500 kc. and 30,000 kc. are being popularized both by commercial and amateur transmitters, it has been found that many of the engineering principles which were satisfactory in the broadcast band are totally unsuitable for good short-wave work. For example, a single tuned stage preceding the first detector in a super gives plenty of r.f. gain, while two stages is generally conceded to be much more than sufficient. As pointed out by Robert S. Kruse in the April, 1934 issue of this magazine, two stages of tuned r.f. preceding the first detector in a short-wave superheterodyne are just about equivalent to a single stage in the broadcast band. That this is so will be evident when it is realized that a tuned r.f. stage operating at 15,000 kc. gives a gain of about ten or so, compared to about a hundred in the broadcast band.

Another consideration is the question of image frequency. There is no doubt about the fact that the only way in which image frequency can be reduced to a negligible quantity is by increasing the number of

Three methods of tuning the antenna system. That shown at A cannot be readily adapted to resonant tuning because of dead spots; those at B and C may be used without any trouble at all, providing the coupling between the primary, P, and the secondary, S, is adjustable.

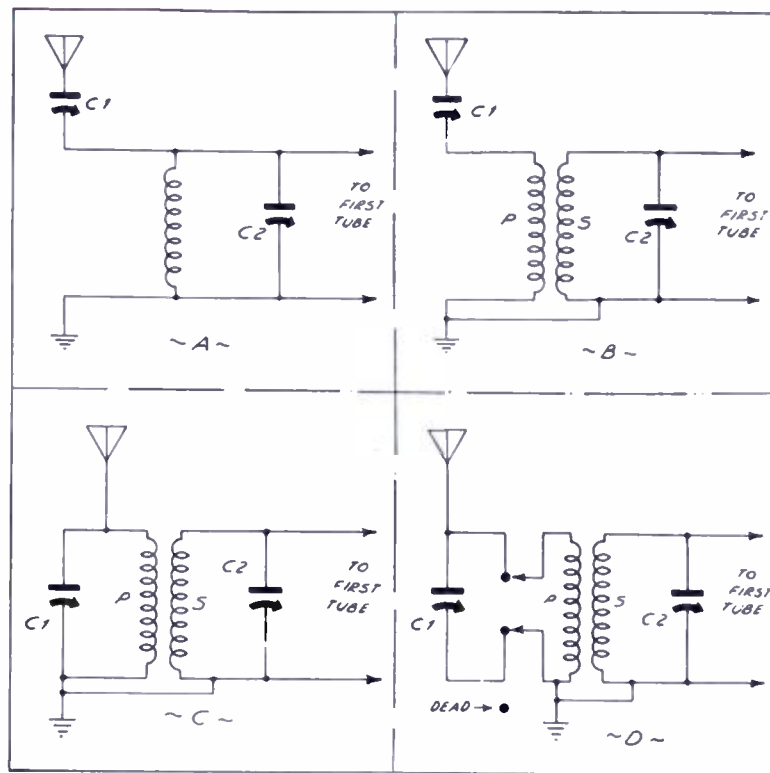

tuned stages preceding the first detector, since the selectivity of a given circuit is limited by commercial tolerances.

It is easy to make statements such as these, but it is quite a different matter to execute them. Fortunately, however, we have recourse to one other method, employed only in a few commercial receivers and in practically no home constructed sets, which can increase the sensitivity considerably, cut down interference, and result in improved overall performance. This seemingly magical scheme is nothing else than the decade-old tuned antenna system, various forms of which are shown in the accompanying figure.

The system at A is quite common among present receivers. The only difference is that the antenna trimmer, C1, should be a completely variable affair of about 50 to 100 mmf. and be controlled from the front of the panel. When tuned to resonance, the antenna will deliver maximum voltage to the grid of the first tube. However, due to the close coupling the set is likely to stop oscillating. This circuit will now be recognized by old-timers as the very simple, but effective, single circuit tuner.

Adjusting Circuit A

It should be realized that a resonant antenna system such as the one suggested at A constitutes nearly a direct short across the tuned circuit. Thus the tube would have difficulty in supplying the losses in both the antenna and the tuned circuit, and we have what is known as a "dead spot." The usual procedure followed in using such a circuit is to adjust the antenna condenser until oscillation is smooth all over the broadcast band. It

should also be noted that if the tube is not of the regenerative type, then the antenna circuit may be resonated by the adjustment of C1 from the front of the panel. Even then the antenna resistance coupled into the tuned circuit may be large enough to broaden the tuning; the remedy, then, is to vary C1 until the tuning is as sharp as required and the signal strength as great as possible.

The Separate Primary

That shown in B operates on a principle similar to that at A, with the exception that the antenna is resonated to its natural frequency in conjunction with the primary P which, usually, is untuned.

Undoubtedly, most of the receivers employing tuned antenna circuits will use plug-in coils, so that the size of P will vary with the coil used. In this manner, it is quite certain that the same condenser will be suitable from 1500 to 30,000 kc.

The circuit at C is similar to that at B with the exception that the antenna condenser, C1, is now in parallel with the primary P instead of in series with it. Its operation, however, is identical with that at C. Condenser C1 is tuned until the signal is loudest.

The constructor usually has no choice as to which of the two circuits—that of A or B—he shall use, since a very simple rule necessitates either one or the other. The system at A must be incorporated when the fundamental frequency of the antenna is lower than that to which the antenna is used; while the system at B is suitable when the fundamental frequency of the antenna system is greater than that of the signal.

(Continued on page 42)

A Lazy Man Listens to Europe

Some practical advice from a practical man

WITH the broadcast set, it is only the occasional man who bothers to calibrate his dial settings. The others discover that their favorite programs come in at 700, or 760 or 860, or whatever it may be, and let it go at that.

But, with the short-wave set, the finding of a favorite program ceases to be a happy-go-lucky affair; and if listening is to be a real enjoyment, it becomes necessary to adopt a systematic method of first finding the secret coil and dial combination, and then tuning at a time when the station is on.

Getting Started

When I first started listening on short waves, I heeded the advice so frequently urged in the magazines: keep a log sheet and to make up calibration curves of dial settings vs. kilocycles. Naturally, my first station was W8XK. It is probably everybody's first station, because it is spattered all over the short-wave landscape. But it was precious little use in calibration, because the announcer failed to mention how many and which of his six wavelengths he was using.

Presently, I got other stations, some with a single wavelength and some with two, and in a day or so I had enough dope to draw approximate tuning curves for the 40-meter and 80-meter coils. I used frequency instead of wavelength for the curves because my tuning condensers are said to be "straight line frequency," and they really are.

By Q. B. Newman

Having done my calibration, I filled the trusty pipe and settled down to enjoy some European programs, which is my real objective on the short waves. Naturally, I turned to "Best Short Wave Stations" in SHORT WAVE RADIO, only to find the list arranged by wavelengths! So I knocked out said pipe and figured wavelengths corresponding to frequencies, and plotted them in the other margin. I then had a sheet of which Fig. 1 is a partial reproduction, and from this sheet I could locate any particular station with reasonable ease and accuracy.

I had to consult the magazine for the times the various stations would be broadcasting, and it very soon became a bore to wade through the list only to find there was no program at the moment. Also, I found there were only four short sections of the curves that were of interest in my particular case. So I decided to indulge in a little band-spreading on the calibration and also to add some time symbols.

The Final Result

The final result is shown in Fig. 2. The right hand scale has one division for each 10 kilocycles, and the corresponding wavelength is the left hand scale, making it easy to dial a station on either basis. The curves show which coils to use. The real merit of this chart lies in the time-table feature. The time of day is given at the top, and each of the stations which are of particular in-

terest to me has the usual broadcasting hours represented by a horizontal line on the station frequency.

This chart is, therefore, all I need for comfortable and indolent listening. A glance at the clock, and a glance down the space for that hour shows who is on. Another glance at the curve for the coil and the dial setting for the station of my preference. *Et, la voila!*

Conclusion

It is very probable that the stations of your fancy are not the same as mine, but the principle remains the same. If your stations put on regular programs, get the times of those programs on your chart and then expand the pertinent sections of your tuning curves so that you can see them.

Above all, use paper with fine subdivisions. Do not attempt to rule your own. Especially, stay away from the miserable sheets with quarter-inch rulings that the radio magazines sometimes publish. I find most satisfactory a sheet about 7 by 10 inches with 10 divisions to the half inch or the centimeter. They are obtainable everywhere and the cost is trivial.

(The charts shown below should not be scaled for extreme accuracy; neither should the spacings be taken as that to be asked for when buying cross-section paper. The type recommended by Mr. Newman is standard, and therefore procurable in almost any stationery store. Don't be in too much of a hurry—take your time.

—Tech. Dir.)

Fig. 1 is merely a calibration curve of the receiver used by Mr. Newman. Four coils are used; therefore, four separate calibration curves are required. This set of curves was not sufficient for the purpose, so Mr. Newman drew the one illustrated in Fig. 2. Here, by merely glancing at the clock, the dial settings for any station previously received may be obtained at once. Note the horizontal lines, which give the number of hours a given station is on the air.

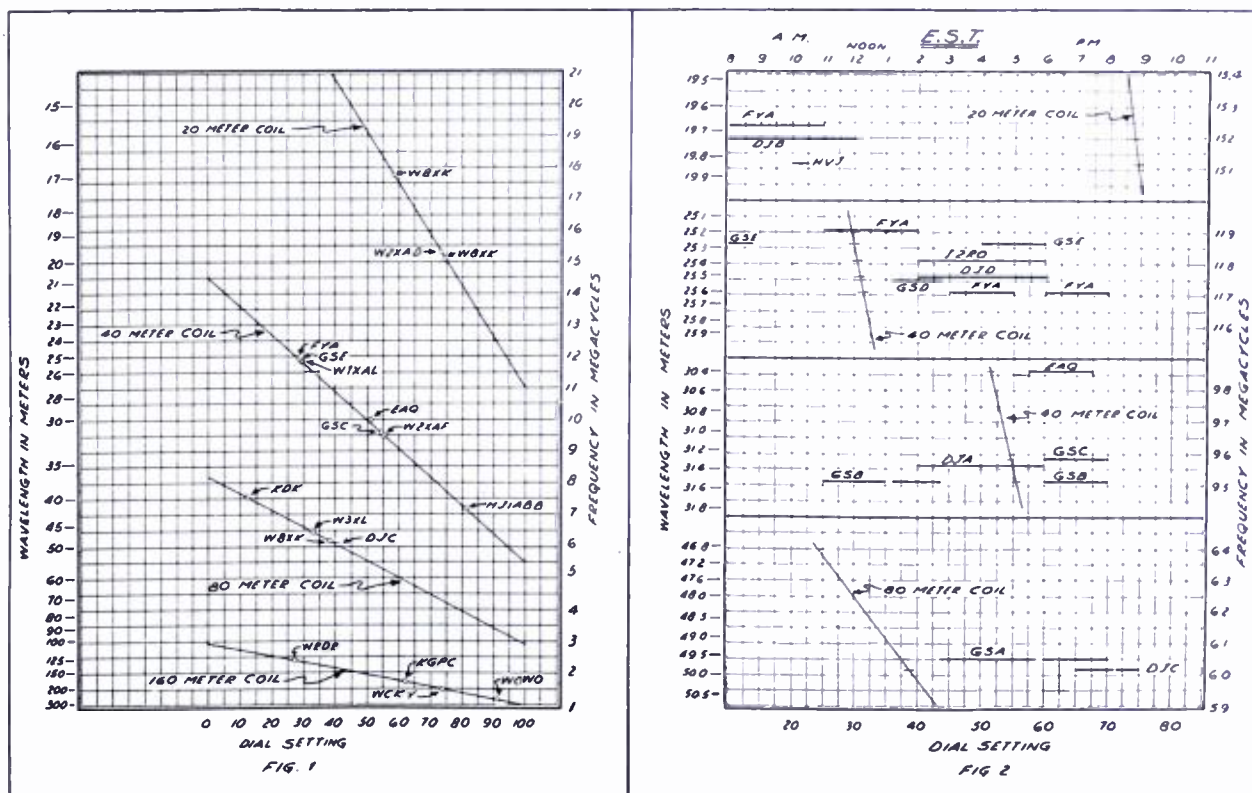

Does the Moon Affect Radio Reception?

(some further notes)

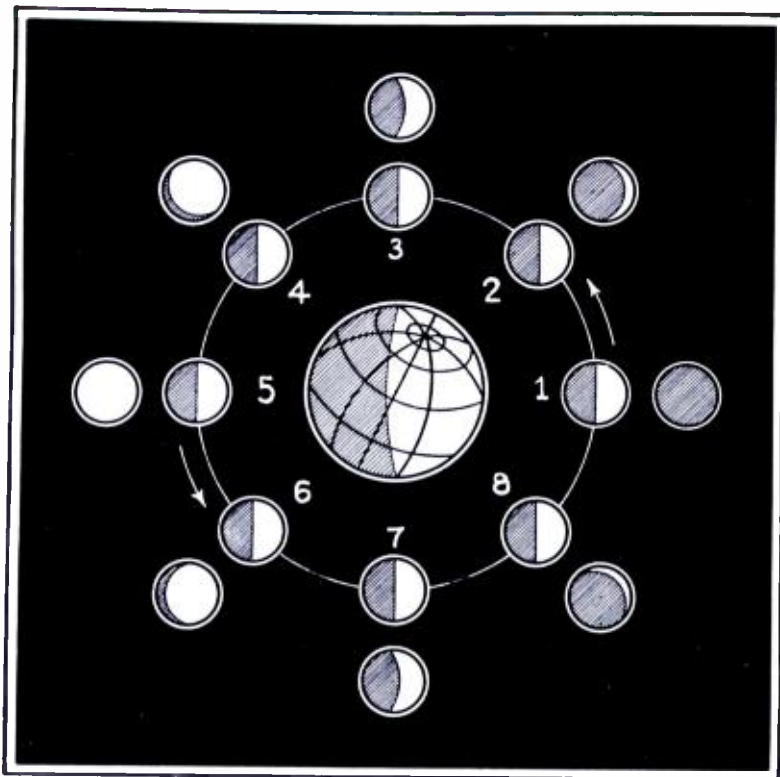

POSITION OF MOON WITH RESPECT TO THE EARTH
With the moon at (1) an observer on earth does not see any moon; at (3) he sees a quarter moon; etc.

SUMMARY: Additional data on the effect of the moon on radio reception have been received. On the basis of these reports an attempt has been made to predict reception conditions for the month of May. It must be emphasized that these predictions must not be regarded as absolutely final; on the contrary, we want readers to check the predictions and advise us; another report will then be made.

By Louis Martin
and C. H. Lane

AS stated in an article published in the December, 1933, issue of this magazine, we had a hunch that reception conditions varied with the phases of the moon—reception was best when the moon was full and poor when the moon was new (no moon). We also published a chart by Mr. L. F. Reading, who compiled information in England on the reception of W8XK, Pittsburgh, Pa. These curves seem to bear out, to some extent, the assertion that reception varied with the phases of the moon. We also outlined various tests that we suggested listeners make in the hope of compiling more accurate data.

Mr. C. H. Lane, of Youngstown, Ohio, performed an excellent job in this respect. He sent in complete reception reports from the middle of November, 1933, to the middle of March, 1934, and it is on the basis of these notes that the writer will attempt to predict reception conditions for the month of May, 1934. *Bear in mind, though, that the predictions herewith may not hold true at all—our analysis may be all wrong.* Nevertheless, we would like every reader to see how closely our predictions are verified. Please do not hesitate to write us about your observations.

General Outline of Results

In the December number it was stated that reception was good when the moon was full and poor when the moon was new. This state of affairs is not strictly true. Whether reception is good or bad depends on the position of the moon with respect to the earth.

The moon traces a path around the earth in very nearly one month;

furthermore, this path closely resembles an ellipse with the earth at one of the foci. This means that, at a certain time during the month, the moon is farther from the earth than at any other time; also, at another time during the month, the moon is closer to the earth than at any other time. These two positions of the moon are known as *apogee* and *perigee*, respectively. That is, when the moon is farthest from the earth, it is said to be an apogee, and, when closest to the earth, it is in perigee.

Review of Reports

Qualifying our statement of receiving conditions above, therefore, it may be said that when the moon is in perigee, receiving conditions are good, and when in apogee, receiving conditions are poor. Let us review the reports of Mr. Lane for the month of January, 1934.

Between the 8th and 14th of January, the moon was in its last quarter, and was also, on January 14th, in perigee. According to our previous data, receiving conditions should be fair and, because the moon is in perigee, signal strength should be boosted a little more. On the average, therefore, we should have had pretty good reception between the 8th and 14th days of January. Mr. Lane's report for this period shows that fading was not serious; static on the average was not serious, and reception fairly good. Reception below 49 meters seemed to be getting worse from the 8th to the 14th, while the bands above 49 meters seemed to be getting better.

From January 15th to January

21st, the moon was in the first quarter, and its position between perigee and apogee, so that we should have had increasing signal strength.

This was borne out, to some extent, by the reports of Mr. Lane. Reception conditions below 49 meters were fair and signals of about the same quality and strength, relatively speaking, for the bands above 49 meters. The general conclusion of his report for this period of time seems to indicate that a levelling off of signal strength throughout the entire short-wave band occurred. Reception conditions were not regarded as poor, although they were only fair.

Between the 22nd and 30th days of January, the moon increased until it was full, and on January 27th was in apogee. It will be interesting to review the reports for this period of time.

Signal strength took a tremendous rise for both quality of reception and volume on about the 25th of January. On the 27th of January, the day the moon was in apogee, Mr. Lane reported that nothing could be heard under 40 meters, the 49-meter band was extremely noisy, one station on 75 meters had good volume but was not understandable, and the police stations came in very well. This would seem to indicate that the effect of the moon in apogee is to cause the signal strength to drop in the bands below about 40 meters.

Between the 28th and 30th, stations on all bands below 40 meters came in with volume and were very clear. The report for stations in the higher bands was unreliable because a severe storm took place during that interval. It seems, though, that signal strength had dropped a bit on the higher bands. Between

the 31st of January and the 7th of February, the moon was going into its last quarter. Signal strength seemed to keep a rather even keel and, in one or two days during this period, certain code stations seemed almost twice as loud as normal. Between February 8th and 13th, the moon was disappearing, and on February 12th was in perigee. Let us see what the reports were for this period. Between this period of time, reception was fair, although static and fading were worse than normal and were especially prevalent when the moon was in perigee.

This more or less detailed report covers only a little more than one complete anomalistic month (from perigee to perigee).

Predictions

In the accompanying table the writer has attempted, with a clear conscience and an open mind, to predict reception conditions on the basis of the data supplied by Mr. Lane and others. If, upon reception of further reports, it is found that conditions are other than listed in the table, then we will investigate the subject further.

Please note the complete absence of theory in this informal discussion. Theoretical speculation is dangerous unless one is equipped

RECEPTION PREDICTIONS FOR THE MONTH OF MAY			
Date	Phase of Moon	Perigee (P) Apogee (A)	General Reception Conditions
May 1 to May 6	Going into last Quarter	May 2 (P)	Signals on all bands should have about the same strength; static and fading intermittent but not too severe. Probably a little better above 49 meters.
May 6 to May 13	Moon disappearing		Reception should be fair, and static and fading should be a bit worse than the previous week.
May 13 to May 21	Increasing to its first Quar.	May 18 (A)	Signals should increase until about the 16th, then decrease until about the 20th; from the 20th on, signals should again increase. Static and fading should be bad during the same time that signal strength is low.
May 21 to May 28	Increasing to Full		A very noticeable rise in signal strength should occur during this period. Static and fading should not be detrimental. In view of the fact that the moon is approaching perigee, signals should increase still further near the 28th.
May 28 to June 4	Going into last Quar.	May 30 (P)	Reception should be about the same as for the period from May 1 to May 6 outlined above.

with quantitative data, of which, incidentally, we have none. Our only reports have been qualitative, and, for this reason, we must limit ourselves entirely to a qualitative dis-

ussion, which seems sufficient.

The writer also wishes to thank the many readers who sent in information of both a theoretical and practical nature.

The Before Breakfast Short Wave Club

THE Before Breakfast Short Wave Club, which was first described in the November, 1933, issue of SHORT WAVE RADIO, is a unique organization open to all short-wave listeners. There are no dues, meetings, minutes or other parliamentary nuisances. It is merely a friendly, fraternal and not too serious organization of early birds who believe in the old adage about catching the worm. The only requirement for membership is two verifications from short-wave phone stations one thousands miles or more from the applicant's location, received any time after 5:00 A. M. and before 9:00 A.M. any day of the week. Verifications sent in to the B. B. S. W. C., are returned promptly to their senders along with a certificate of membership suitable for framing. This certificate measures 8½ in. by 11½ in. and is printed on high grade paper.

We do not make any distinction between short-wave relay broadcasting stations, commercial radio-phones, amateur phones, experimental stations, and ship stations. Any station that operates below 200 meters and uses voice transmission is a legitimate catch for the short-wave listener, who is interested only in the feat of reception itself and not in the musical programs, political propaganda and private conversa-



A reduced reproduction of the diploma issued, free of all charges, to all those who can qualify. See text.

tions that fill the air. It is really much more of an accomplishment to bring in an amateur station using perhaps only ten or fifteen watts of power than a powerful broadcasting station using ten or fifteen kw.

Your letters and cards will un-

doubtedly contain valuable "dope" on wavelengths and operating hours of elusive stations, which we will publish for the benefit of less fortunate listeners.

Address your verifications and applications for membership to the Before Breakfast S. W. Club, care of SHORT WAVE RADIO, 1123 Broadway, New York, N. Y., and be sure to enclose a large stamped and addressed envelope for their safe return.

Zero Beating

You can tell when you have zero-beated a station by turning the tuning condenser a hair's breadth above and below the point at which the signals are understandable and clear of whistling. You will hear a whistle each time, as each time you move the condenser you change the frequency of the local receiver circuit and therefore cause a beat note to be set up which is heard as a whistle. Zero-beating is an excellent means of fishing out very weak signals, because the receiver is in a very highly sensitive condition when it is oscillating. Many weak and distant stations, that you cannot hear at all with the set thrown just out of oscillation, you at least will be able to identify if you zero-beat them.

Output Transformer Chart

Tube Type	How Used	Plate Voltage	Load Impedance	Type of Output Transformer	Tube Type	How Used	Plate Voltage	Load Impedance	Type of Output Transformer
2A3	Single Tube, Class A	250	2500	A	46	Single Tube, Class A Triode	250	6400	E
2A5	Single Tube, Class A Triode Pentode	250 250	3000 7000	A B		Two Tubes, Class B	300 400	5200 5800	E E
	Two Tubes Push-Pull Class AB Triode Fixed Bias Self Bias	350 350	8000 8000	B B	47	Single Tube, Class A	250	7000	B
6A4 (LA)	Single Tube, Class A	100	11000	C	48	Single Tube, Class A Tetrode	96 125	1500 1500	A A
		135	9500	B or C		Two Tubes, Push-Pull Class A Triode Tetrode	125 125	1250 3000	A A
		165	8000	B	49	Single Tube, Class A	135	11000	C
		180	8000	B		Two Tubes, Class B	180	12000	C
10	Single Tube, Class A	250 350 425	13000 11000 10200	D C C	50	Single Tube, Class A	300	4600	A or E (Pref.)
12A	Single Tube, Class A	90	5000	E			350	4100	A or E (Pref.)
		135	9000	B			400	3670	A (Pref.) or E
		180	10650	C			450	4350	A or E (Pref.)
19	Single Tube, Class B	135	10000	C	53	Single Tube, Class B	250	8000	B
31	Single Tube, Class A	135	7000	B			300	10000	C
		180	5700	E	59	Single Tube, Class A Triode Pentode	250 250	5000 6000	E E
33	Single Tube, Class A	135 180	7000 6000	B E		71A	Single Tube, Class A	90	3000
38	Single Tube, Class A	100	15000	D	135			3000	A
		135	13500	D	180	4800	E		
		180	11600	C	79	Single Tube, Class B	180	7000	B
		250	10000	C			250	14000	D
41	Single Tube, Class A	100	12000	C or D	89	Single Tube, Class A Triode Pentode	160	7000	B
		135	10400	C			180	6500	B or E
		180	9000	B			250	5500	E
		250	7600	B			Pentode	100	10700
42	Single Tube, Class A Triode Pentode	250	3000	A	135	9200		B or C	
		250	7000	B	189	8000		B	
Two Tubes, Class AB Triode Fixed Bias Self Bias		350	8000	B	250	6750		B or E	
		350	8000	B	Two Tubes, Class B Triode		180	13600 ¹ 9400 ²	D B or C
43	Single Tube, Class A	95	4500	E					
		135	4000	E					
45	Single Tube, Class A	180	2700	A					
		250	3900	A or E					
		275	4600	E					

¹For 2.5 watts output. ²For 3.5 watts output.

The chart shown herewith lists all of the tubes commonly designated as output tubes. These tubes must be distinguished from such types as the 30, 27, etc., which, although they may be used as output tubes, are not considered as such. In other words, the 30, 27, etc., when used as output tubes, usually employ earphones directly in the plate circuit. The chart here is for the purpose of designat-

ing, within limits, the tubes that may be used with output transformers.

All tubes followed by the same designation may be used with the same transformer. Thus the 2A3 in the triode connection, the 42 connected as a triode, and the 45 with 180 volts on the plate may be used with the same transformer.

These designations bring to light

another important point not realized by the average experimenter. For maximum undistorted output, the type of output transformer used depends upon the operating potentials. Merely because you use a 12A in the output circuit is no reason why the same transformer must be used to obtain maximum efficiency under all operating conditions. The plate impedance, and, consequently, the ratio

of the output transformer, changes as the plate, screen-grid and bias voltages change.

Here, then, is a means whereby the quality and efficiency of an output tube may be changed. If you have a transformer that is not designed for a particular tube you wish to use, you may match the impedances in some cases by varying the plate voltage on the output tube. Of course, the bias voltage must also be changed in proportion.

It is to be noted from the chart that five different types of output transformers are required. These five do not match exactly the load impedances for every tube. Certain tubes may be used, with about equal efficiency, with two different types of transformers, and are so stated.

The letters A, B, C, D, E, used to designate the types of output transformers, have no special significance in themselves; they were merely chosen because some designating symbols had to be used. Technically, an output transformer is designated by its ratio, primary impedance, and secondary impedance. However, the average constructor has no means of determining these factors if they are not stated explicitly by the manufacturer. For this reason, a transformer is distinguished by the type tube from which it is designed to operate. So, we have type 47 transformers, type 45 transformers, etc.

This method of notation gives the chart its value. The fact that a certain transformer has a resistance of 1000 ohms and an impedance at 1000 cycles of 50,000 ohms means absolutely nothing to the non-technical man. What does mean something is the fact that the transformer is designed to operate from a given tube into a given speaker. And so, if you have a transformer, and you know the tube from which it is designed to operate, then, by referring to the chart, you can tell from what other output tubes and operating conditions the same transformer can operate. All transformers having the same designations are the same.

While on the subject of output transformers, there is one point that needs to be emphasized. The resistance of the primary of an output transformer has absolutely nothing to do with the type of tube from which it operates. And by resistance is meant the d.c. resistance, the kind you measure with the garden variety of ohmmeter. So many readers write in and state the d.c. resistance of a particular output transformer and ask us to tell them the tubes it is good for that we would like to clear up the matter right here and now.

The ideal transformer would have a primary of zero resistance. Simply because science has as yet been unable to invent a wire conductor that has zero resistance (at normal tem-

peratures!), and simply because output transformer windings must be wound with wire, primaries have resistance. It is a liability rather than an asset, and is considered only when detailed specifications are required. The important things are primary impedance, secondary impedance, leakage reactance, etc. Even these details, however, are of little practical use; the only other practical information that you may want is the ratio of the transformer.

To compute the ratio of an output transformer required for a certain tube and voice coil, simply divide the *load impedance* required by the output tube (which can be obtained from the chart) by the impedance (very nearly equal to the d.c. resistance) of the voice coil of the speaker used; then take the square root of the answer. Thus

$$\text{Ratio} = \sqrt{\frac{Z_{\text{tube}}}{Z_{\text{r.c.}}}}$$

Example: A type 45 tube with 250 volts on the plate is to drive a dynamic speaker with a voice coil impedance of 10 ohms (a common value). What is the ratio of the required output transformer? Dividing 3900 (the required load impedance) by 10, we get 390; the square root of 390 is about 19:1. A ratio of 20:1 is close enough.

—L. M.

A New Volt-Ohm-Milliammeter for the Experimenter

THE novel little continuity tester and voltmeter described in our May issue seemed to be just the thing for experimenters. Too many people connect high voltages helter skelter without taking the trouble to make a few simple measurements. The same idea goes for resistors. Resistor markings wear off, color coding sometimes fades and the constructor finally has to resort to the good old fashioned method of guessing.

The Ham Tester described has several limitations—the ohmmeter range is limited, while no provision is made for the reading of current. To complete the tester, it is desirable to extend its usefulness by incorporating these features.

The schematic circuit shown here with enables current up to 50 ma. in one range, and up to 500 microamperes in another range. Also, voltmeter ranges up to 750 volts are available, and three ohmmeter scales, capable of direct reading from $\frac{1}{4}$ to 2 megohms, complete the tester.

This inexpensive tester has several features that make it modern. First, the meter has a sensitivity of 2000 ohms per volt—twice the sensitivity usually found in testers of this type. Second, only two tip jacks are employed. The use of but two jacks dispenses with the necessity of changing the leads as you switch

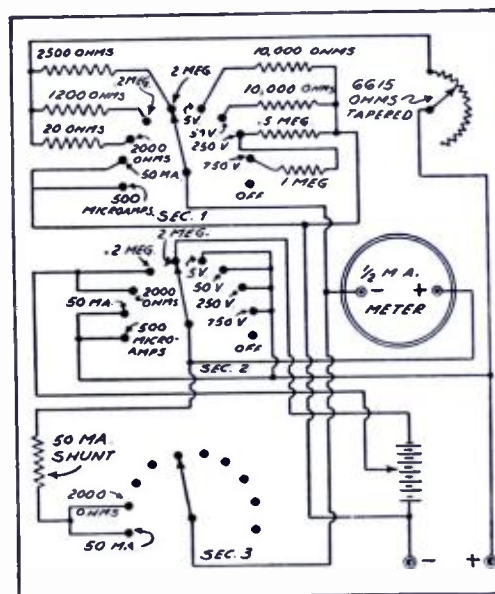

Schematic circuit, with all values, and photograph of the new tester briefly described in this article. The three arms shown are ganged together, so that a single switch is all that is required for operation of the tester.



The instrument shown has a sensitivity of 2000 ohms per volt, a value twice as high as ordinarily found in meters of this type. This high sensitivity means that the voltage as read by the meter will be more accurate than is ordinarily obtained.

from the ohmmeter to voltmeter to milliammeter. The third feature is the use of a new switch with a special banjo, so arranged that the switch arm locks into position at every point of contact.

The 500 microampere scale should be especially valuable to the "ham" for making grid current measurements in adjusting overbiased class A, class B or class C amplifiers. The additional range of 50 ma. has been found the best value for general, all-around current measurements.

The voltmeter scales are, perhaps, the most useful to the short-wave receiving experimenter. The number of ranges and the value of each are those most adaptable for receiving sets. Furthermore, the high sensitivity eliminates voltage fluctuation with the application or removal of the meter from a circuit having a high resistance.

In general, use that voltmeter range that gives the highest reading, and then increase the range until a lower scale reading on the highest possible range is obtained. This will insure the highest degree of accuracy on any type of instrument.

It may be easily and quickly assembled from a kit of parts supplied directly from the manufacturer. It is known as the model 403 Multitester, and is produced by the Radio City Products Co., 48 West Broadway, New York, N. Y.

Filament Supplies for 2-Volt Sets

A non-technical description of the characteristics of A batteries for 2-volt tubes

CONVENIENT sources of filament supply have always been a problem. In the early days of radio the more or less cumbersome storage battery was the only reliable source of supply for this purpose. The storage battery, in spite of its efficiency, has many disadvantages: it must be recharged frequently; it must be serviced from time to time by someone with a knowledge of what he is doing; and it must be handled carefully. In metropolitan areas, where charging facilities were close at hand, these difficulties were not serious; but, in the rural sections of the country, especially in localities where power lines were not available, these obstacles could not be overcome.

With the widespread use of a.c. tubes and the installation of electrical power lines in small towns, the storage battery problem solved itself, although the same difficulties still confront radio set owners in un-powered districts.

It might seem, therefore, that city dwellers have no further use for batteries, but such is far from the case. Thousands of people still construct their own receivers, and a good proportion of these constructors do not care for the complicated transformer-filter-rectifier systems inherent in a.c. powered sets. Furthermore, in short-wave receivers, the *relatively* noisy operation of a.c. powered sets makes the use of batteries for both plate and filament supply all the more desirable.

A series of 2-volt tubes designed for battery operation gave further impetus to the use of batteries for filament supply. These tubes are comparable in efficiency with a.c. tubes, and those designed for the output stage deliver more than sufficient volume for ordinary use.

Two types of A supply have been developed especially for the 2-volt tubes. These are the Air Cell and the new dry A batteries made by Burgess and General. The operating data and characteristics of each will be given.

The Air Cell

The Air Cell is neither a dry nor a storage battery, a "dry" battery being defined as one that does not contain a liquid, and a storage battery being defined as a secondary cell—one that can be recharged. In this respect the Air Cell is unique. It is not a dry battery because it does contain water, and it is not a storage battery because it cannot be recharged. Its redeeming feature is that it de-

livers a practically constant voltage throughout its entire life, thus dispensing entirely with rheostats and resistors that continually need readjustment as the voltage of the source drops.

This statement does not mean that 2-volt sets using the Air Cell require no fixed resistor at all. Every 2-volt set should have in it a fixed resistor of such value that the filament voltage is 2.2 when fresh, which drops to about 1.8 volts after 600 ampere hours have been used. The limits of 1.8 and 2.2 volts are the limits of operation of the 2-volt series of tubes.

The Series Resistor

The size of this resistor depends upon the number of tubes in use, and, when once determined, does not have to be changed during the entire life of the battery. The insertion of this resistor is very important, and, fortunately, its value can be computed easily. The terminal voltage of the Air Cell at about .5 ampere drain (it does not vary much with load changes) is 2.53 volts; the resistor should cut this voltage down to 2.2 volts. The value of the required resistor, then, may be determined by dividing .33 by the filament drain of the set in amperes. Thus, if two tubes are used, the resistor should have a value of $.33/.12$, or 2.75 ohms, if each of the tubes draws .06 ampere.

It may be difficult to secure a re-

sistor of this value. If so, then a rheostat of about 3 ohms—which value will be sufficient for most receivers—mounted in some inconspicuous corner of the chassis will do the trick. Merely adjust it once for 2.2 volts at the tube terminals and leave it alone.

The Air Cell voltage will drop uniformly from 2.2 to 1.8 volts throughout its entire life, regardless of whether the drain is uniform or intermittent, so long as the maximum current does not exceed 650 milliamperes. Currents greater than this value will decrease the life of the battery considerably. It is important that the instruction sheet should be studied carefully.

Dry Batteries

The General dry A battery is composed of a number of special dry cells connected in series-parallel. The parallel connection gives the battery its long life and the series connection—there are two parallel banks connected in series—develops the 3 volts of the battery.

The characteristics of this dry battery are the same as those of any ordinary dry cell, so that no special operating precautions need be taken. The General dry battery is available in two sizes: the type P-126-X-2 and the type P-246-X-2. The former is rated at 600 service hours and the latter at 1200 service hours.

The type P-246-X-2 battery is 13 inches long, $6\frac{3}{4}$ inches wide, and $8\frac{3}{4}$ inches high; packing weight is 50 pounds. The type P-126-X-2 is 13 inches long, $4\frac{1}{4}$ inches wide, and $6\frac{3}{4}$ inches high; packing weight, 25 pounds.

The "Service Hour"

The service-hour ratings must not be confused with ampere-hour ratings. Ampere hours are the number of amperes flowing multiplied by the number of hours that that same current is being drawn. Another definition is the average current drawn times the average time the current flows. General defines a "service hour" as $\frac{1}{2}$ ampere used 3 hours per day. This corresponds to .5 ampere hour. The corresponding ampere-hour ratings of the two types of batteries are, therefore, 300 and 600.

An important point in connection with the service-hour rating is that it must be used 3 hours per day at $\frac{1}{2}$ ampere in order for the stated ratings to hold. Any deviation from this hourly consumption basis alters the rating of the battery. This is not peculiar to the General battery,

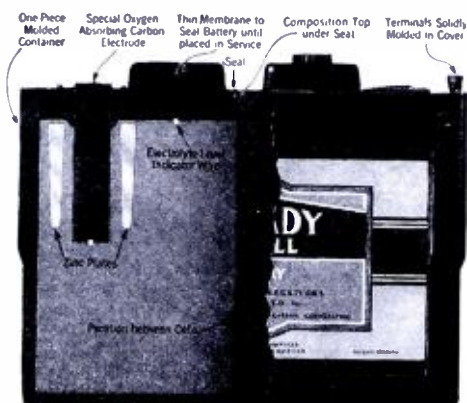

Photographs of the exterior and interior of the Air Cell, designed especially for 2-volt receivers. It is not a storage battery.

but is characteristic of all dry cells. Everyone is more or less familiar with the fact that dry batteries recuperate when left idle for a time. This recuperation is taken into consideration when rating the battery in service hours.

In view of the fact that the terminal voltage is three volts, a resistor must be kept in series with the filaments of the tubes in order to maintain the filament voltage at the proper value, 2 volts in our case. The size of this resistor is not fixed, as in the Air Cell, but must be changed as the life of the battery decreases. To provide for this, General has incorporated a tapped resistor on the top of the battery, as may be seen from the photograph. The value of this resistor may be computed by Ohm's law.

The Burgess A battery is made up of two groups of twenty parallel connected dry cells, these two groups being connected in series to give the required 3 volts. The volume efficiency of 1250 ampere



View of one model of the General A battery, the characteristics of which are described.



The Burgess A battery. Both the General and the Burgess are dry batteries; the Air Cell is not "dry."

hours per cubic foot (200 ampere hours per battery) is obtained by a honeycomb method of packing, which reduces the volume required for the battery. The ampere-hour rating of this battery is also based upon the fact that the battery recuperates during idle periods, and, as stated previously, should be taken into consideration when choosing a battery for 2-volt receivers.

The type 1040 A battery is 6 $\frac{5}{8}$ inches high, 11 $\frac{1}{8}$ inches wide, and 4 inches deep; its weight is 14 pounds. The series resistor required for operation is not standard equipment; it is supplied only on order.

Testing the Batteries

As with all dry batteries, testing may be done with an ammeter. This procedure, although satisfactory for a single cell, is not recommended when a number of cells are used in combination. The reason for this becomes apparent when it is realized that one poor cell may discharge the entire battery, and that extremely heavy currents are liable to damage one or more cells. The proper procedure—and this goes for the Air Cell, too—is to measure the terminal voltage of the battery when full load is applied. When this voltage drops below 1.8, the battery should be discarded.

No doubt readers will be able to form their own opinions as to which battery is best suited for their purpose. The first thing to determine is the ampere hour or service hour capacity that suits your requirements. The factor of cost will then adjust itself, as there is not much duplication in this respect.

Then, again, the type of receiver will, to some extent, determine the type of battery. As pointed out previously, the Air Cell cannot be operated on all types of receivers. Too many tubes or a dial light may cause the drain to exceed that recommended for the Cell. On the other hand, dry batteries are not subject to serious current limitations, and as much as 2 or 3 amperes may be drawn for short periods without damage to the cells.

Also do not forget the fact that the Air Cell requires a series filament resistor, just as do the dry batteries. The only difference between the two resistors is that the one for the dry batteries must be variable, while one for the Air Cell may be fixed.

The fact that the Air Cell requires some attention, although at infrequent intervals, may or may not be a handicap. On the other hand, the fact that its terminal voltage is remarkably constant may offset this to some extent. All these items must be carefully considered.—L. M.

Characteristics of the 6C6 and 6D6

THE desirable characteristics of the type 57 and the 58 tubes have been made available in the six-volt tube series by the introduction of the 6C6 and the 6D6. Except for major differences in heater voltage and heated current, and minor differences in grid-to-plate capacitance, the 6C6 and 6D6 are identical with the 57 and 58, respectively.

Plate, screen and grid voltages for the 6C6 and 6D6 are the same as recommended for the 57 and 58. The latter, however, are seldom operated at plate supply voltages below 250 volts, whereas tubes in the six-volt series are often used in a.c.-d.c. re-

ceiver circuits where the plate supply voltage does not exceed 100 volts. This application note provides information on the 100-volt operation of these tubes as amplifiers, detectors and mixers. The values apply equally well for the 57 and 58.

Due to the high plate resistance of the 6C6, the characteristics for 100-volt operation are not greatly different from those for 250-volt operation.

Detector Operation of the 6C6

The following optimum conditions for operation of the 6C6 as a self-
(Continued on page 38)

Characteristics as Amplifiers

	6C6	6D6	
Heater Voltage	6.3	6.3	volts
Heater Current	0.3	0.3	ampere
Plate Voltage	0	100	volts
Screen Voltage	100	100	volts
Control Grid Voltage	-3.0	-3.0	volts
Suppressor	Connected to Cathode at Socket		
Amplification Factor	1,185	375	
Plate Resistance	1.0	0.25	megohm
Mutual Conductance	1,185	1,500	micromhos
Plate Current	2.0	8.0	milliamperes
Screen Current	0.5	2.2	milliamperes

Characteristics as Detectors

	I	II	III	
Heater Voltage	6.3	6.3	6.3	volts
Plate-Supply Voltage	100	100	100	volts
Screen Voltage	25	30	12	volts
Control Grid Voltage	1.52	1.83	1.16	volts
Cathode Resistor	13,700	10,000	13,000	ohms
Suppressor	Connected to Cathode at Socket			
Cathode Current (no signal)	0.110	0.183	0.063	milliamperes
Plate Resistor	0.5	0.25	1.0	megohm
Grid Resistor*	1.0	0.5	1.0	megohm
Blocking Condenser	0.01	0.01	0.01	microfarads
R.F. Input Signal (r.m.s.)	1.2	1.6	1.05	volts

*For following amplifier tube.

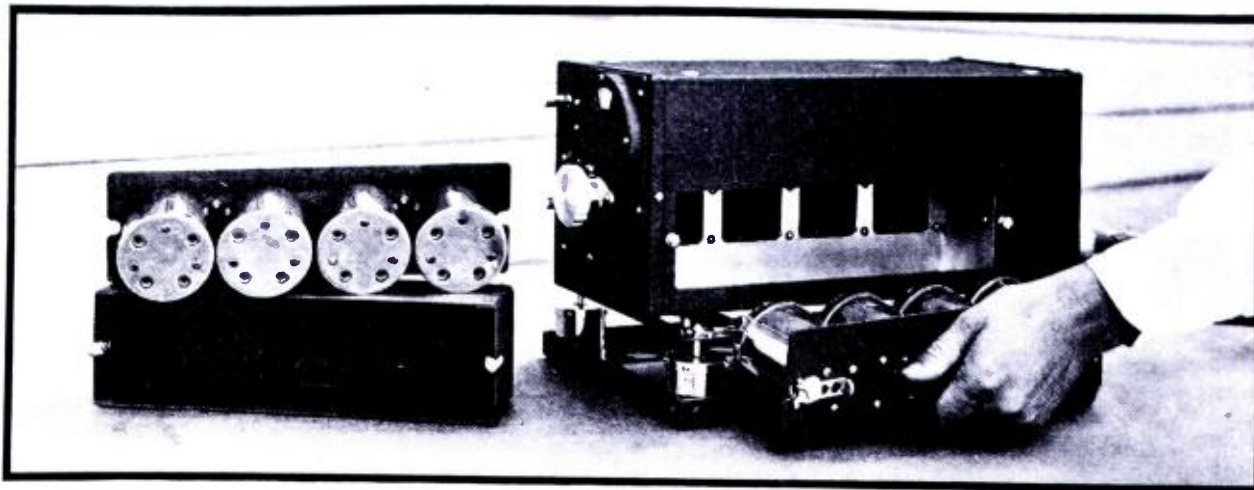

An example of good shielding. Note the man-sized shield cans that are able to shield a coil properly.

Shielding at High Frequencies

By Robert S. Kruse*

IN the days before screen-grid tubes, the better broadcast receivers had good tuned coils. They were kept good by using sufficiently large shielding cans of the proper material and of adequate thickness. More pointedly, the coils were some 2 or 2½ inches in diameter, the cans twice as big, and in the most costly sets they were of copper.

Since then we have slipped rather badly as to tuned r.f. amplifiers. Screen-grid tubes and superheterodyne circuits have made high-gain sets so easy to produce that nobody seems to worry about the t.r.f. amplifier; indeed, some sets dispense with it altogether and work directly from the antenna into the first detector, or the "translator," as Dr. Cutting calls it. That this is quite a long ways from good practice is admitted fairly generally by designers, who feel helpless to improve matters in the present "price" market.

Users do not seem to appreciate that noisy short-wave performance, full of interference, is due to just this neglect of the t.r.f. amplifier at the front of the set. Neither do they seem to be generally aware that a screen-grid tube at 20 meters is just about as poor an r.f. amplifier as the 27 was in the region of WABC, and, therefore, requires equally good design-care in the associated equipment if we do not wish to tolerate bad performance. It is most emphatically *not* true that we can make up for a bad front end by using a high-gain, high-selectivity intermediate-frequency amplifier. This attempt is basically wrong for two reasons:

A—t.r.f. gain is far quieter than i.f. gain.

B—t.r.f. gain improves the image-ratio and reduces tendencies toward adjacent-channel overloading of the translator.

We would seem to have here enough argument to show that even in a superheterodyne there is ample

reason for a really good t.r.f. amplifier. Now let us see what it must be like to be good.

It is so manifest that it must use high-quality insulation in the tuning condenser, and a good grade of sockets, that detailed discussion will be waived. The coils need stressing. Now, as in 1925, a good coil is *never* a small coil. It is not true that a big coil is always good—it may be very bad, indeed. It is not even true that a skeleton coil is a good coil, unless the form be substantial as well as low-loss, and the varnish be of a sort that does not run the losses up in moist weather. Big bad coils may be a lot worse than little coils that are being as good as a little coil can be.

But suppose we have a fair coil, big or small—the performance of the stage can still be very bad if we do not shield and de-couple properly. This gets us to our real story—what is proper shielding and de-coupling in a short-wave receiver?

Shielding and De-Coupling

Suppose that we have a model receiver a new type set down before us and are wondering if the thing does have adequate shielding and de-coupling? Are the coils good enough?

Let us see how far we can go to-

SUMMARY: *What are the criteria for good shielding? This query, in a nut-shell, is what this article answers, and in characteristic Kruse style.*

No beating around the bush, no meaningless generalities—this article gives you the low-down on 1934 shielding problems. Large shield cans and leads shielded with tubing instead of braiding are two of the recommendations made by the author.

ward useful answers without calling in a laboratory.

In a properly tuned r.f. amplifier the ideal condition is that in which the tuned circuits have no coupling whatever except through the tubes which lie between. Then the tuned circuits act as selectors and the tubes as amplifiers.

How do we approach this condition?

Theory of Shielding

To start with, the largest r.f. current will, of course, appear in the tuned circuits, namely, in the coils, and in the leads between condensers and coils. Therefore, our first step is to enclose the large-current parts in shields. Now, shielding a current-carrying part is effective only if the shield, also, is carrying a current. Therefore, our shield must be a closed circuit to be really effective, and the shield-current must flow in the opposite direction to the coil-current. The current-direction will take care of itself, and so will the current. We need but provide the path in which it will be possible for the coil to induce a secondary current. Let us look at Fig. 1. At A we have an unshielded coil, the dotted lines showing the general shape of the resulting magnetic field. At B we have placed a metal tube around the coil, and secondary currents in the tube are squeezing the coil's own field together, so that it takes up less room—but it still leaks out at the ends. At C we have closed up the ends of the coil can so that wherever the coil's field goes it will immediately produce a shield-current which results in a field that drives the coil's field back.

To make these changes in the coil's field is easy enough; but to do it without spoiling the coil is not so easy. The can must not crowd the coil too closely, else the coil's capacity goes up and its inductance goes down. Some of this happens anyway, but we can avoid overdoing it if the can is twice as big both ways—diameter and length—as the

*Consulting Engineer.

coil. The can resistance must be low, else we cannot produce enough shielding current in it without taking too much power from the coil. A silver can would be the ideal thing, a copper can is next best. The thickness for short waves need not be very great, No. 20 gauge being enough, a heavier gauge being better. Aluminum is often used for economy, but in sets designed without cost limitations copper is preferred. A particularly bad way to save money is to use a raw steel chassis as the bottom of the can. This runs up losses and spoils the coil shielding. A can-cover should be mounted in the chassis (or onto) so that the can can be pressed down with some overlap.

Shielding the Leads

We are not yet done with the tuned circuits. We must still shield the leads between the coils and the tuning condensers. The cheapest and poorest way is to strip metal braid over them and ground it to chassis and condenser. This runs up the capacity and the losses. A rigid metal conduit is better, and not uncommon. Its design should be such that the wire is shielded from the view of the next tuned circuit without having to run solidly against much metal. Often a good chassis design permits us to locate the tuned coils so that the leads dive through one metal wall into the compartment of the condenser "bath-tub," in which lives the particular tuning condenser we wish to reach. The "low" end of each tuned circuit should have its own return wire to the rotor of the correct tuning-condenser section. See Fig. 2, in which A is good, but B is bad because the return currents both use the shaft for a return-alley, and are likely to fight.

We have already said that the tuning condenser must have separate returns to each rotor section. No altogether satisfactory way of doing

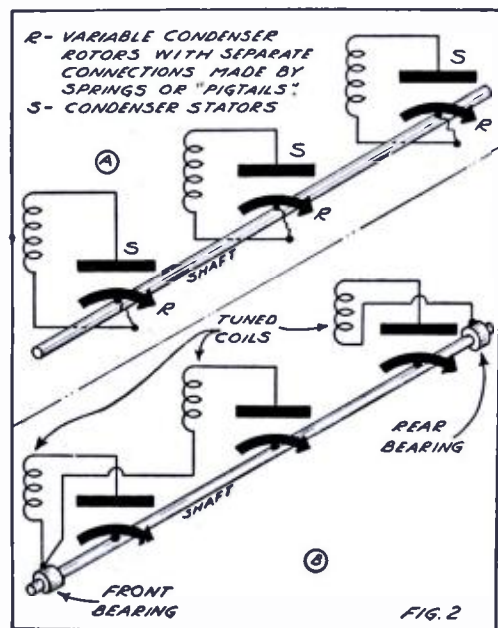

Connections to a condenser gang should be made as shown at A—right to the individual rotors of the separate units.

What the shield can does to the flux from a coil. At A, the coil is unshielded; at B, the shield is placed parallel to the axis of the coil, confining its field; at C, the top is closed up; and at D, the dimensions of a good shield can. With a can of these dimensions, the flux is not crowded "back into the coil," but is given plenty of room; it is also prevented from wandering all over the set.

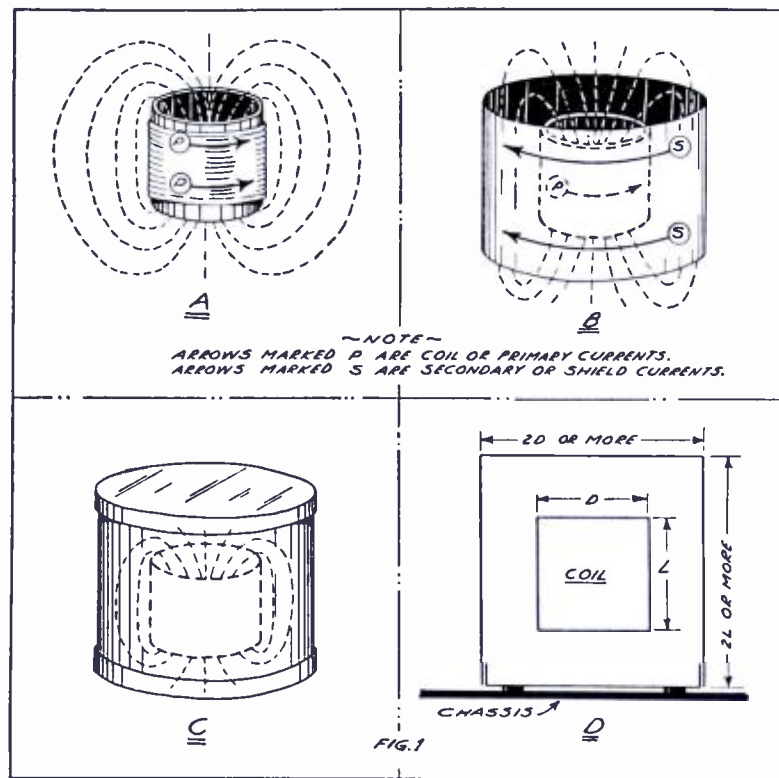

this is known to me. Flexible connectors in time twist or break, spring contacts in time get dirty or wear. However, if well made they last a very long time.

The Condenser Gang

The shielding of the condenser gang is usually well taken care of by the condenser maker, but some of the tests we are about to mention may expose a need for adding "fences" between sections. In the case of the condenser we are not dealing with current-shielding as in Fig. 1. The condenser field is electric instead of magnetic. A simple sheet-metal fence is therefore effective.

The tube-shielding also is electrical instead of magnetic, with one exception. Most of the tubes in the set simply require to be surrounded by the ordinary tube "cans," taking care only to avoid close-fitting cans, as they raise the capacity and spoil short-wave amplification. The leads running to the top caps of r.f. tubes are essentially voltage leads, hence they also may be shielded by mere fences, not too close. The metal-braid idea is as bad here as in the tuned circuits.

Only in the case of the rectifier tube need we think about magnetic shielding, and then we are talking about the 60-cycle magnetism of the power transformer. In some sets now on the market a considerable hum-reduction may be accomplished by dropping a length of iron pipe down over the rectifier! It must have holes near the bottom to permit air to enter. This plumber's chimney causes the tube to run cooler. The real fault is that the power transformer is bad and has too much magnetic leakage. The rectifier is the victim because it happens to be near.

Of course there are other r.f. currents in the system besides those in

the tuned circuits. In Fig. 3A, if we start to follow the r.f. plate current down from the plate, we find that it first passes through the r.f. transformer primary, inducing a relatively large current in the tuned secondary—but it does not stop there; it goes right on, and, accordingly, we supply the plate bypass C₁ to allow it to go back to the cathode of the tube, rather than to allow it to run all over the set via the B supply leads. This is generally enough in a broadcast receiver, but not ordinarily satisfactory in a short-wave receiver. For short-wave work we not only allow the r.f. to go through C₁, we compel it to by adding the resistor R, of about 2500 ohms. The d.c. drop through this is less than 10 volts in most cases, seldom over 20 volts, and the effectiveness of C₁ is increased several hundred times. An r.f. choke may be better, but is quite likely to be a good deal worse because it may produce wrong couplings with other r.f. chokes. If used, it should be individually shielded.

In most modern receivers there may be some system of automatic volume control, generally calling for some way of feeding adjustable bias to the grids of the r.f. tubes. The grid leads through which this bias is fed are, of course, carrying r.f. grid currents unless prevented from doing so. Accordingly, they, too, should have r.f. bypasses to cathode (chassis as a second) and be de-coupled by means of a series resistor of about 100,000 ohms, as suggested in Fig. 3B. This has nothing to do with the need for an audio filter required between the detector output and the grids of tubes under automatic volume control.

Very well—our "eye inspection" seems to show all of these things in the set. How can we tell if they are done well and effectively, without buying a microvoltmeter and other costly devices?

Again let us hark back to the 227 days. Do you remember that we used to test for proper neutralization by turning off a filament, then listening while we adjusted the neutralizer until the signal disappeared, even when the set was carefully re-tuned for it? The idea, of course, was that we were then rid of stray capacity couplings.

Do you remember also that sometimes it would not work until we had moved one of the tuned coils a bit so as to get minimum coupling?

Those ideas are good in 1934.

We tune in a signal and then disconnect the filament circuit on one side of the first r.f. tube. Something sounding a good deal like silence ought to come out of the headset or loudspeaker. If not, we have one of two things to look into:

1—Defective or inadequate shielding.

2—Defective de-coupling of the plate and grid leads—the ones meant to carry only d.c.

This sounds simple, but it isn't.

I can't set down any simple rule that will catch all mistakes. Suppose we take a few examples to give you a general idea of the procedure.

Conclusions

Suppose we find that, with the first tube extinguished, some nearby or fairly strong station is still coming through, with almost no tuning. This sounds as if it were being picked up by the detector grid lead or by the wiring outside of the tuned circuit—or possibly the 110 volt line. Shield, bypass and filter temporarily at these points and suddenly the thing will drop out, unless we are wrong, and the signal is arriving by another route—overloading of an early tube. Don't use too terrific a signal and this second error will not take place.

Suppose, instead, we find that the signal tunes sharply enough, but does come through with the first tube turned off, maybe even with both t.r.f. tubes turned off—and we hope you have a 1934 set with two t.r.f. stages. It is then fairly clear that the signal is getting into one of the later tuned circuits, either because that coil-can is bad (or the leads to the tuning condenser badly shielded) or else there must be some capacity coupling that hasn't been taken care of—or perhaps a conductive coupling.

As a first check put another can down over the tuned input coil of the first r.f. tube whose filament is on. Two bad shields are a pretty good coil shield when taken together so almost any can that goes in will do. If this isn't it, get out a lot of .01 mfd. mica condensers, 2500 ohm and 100,000 ohm resistors and de-couple and bypass everything in sight until you catch the offending spot—then pull these devices off one at a time until only the necessary ones are left.

Sometimes the whole business is

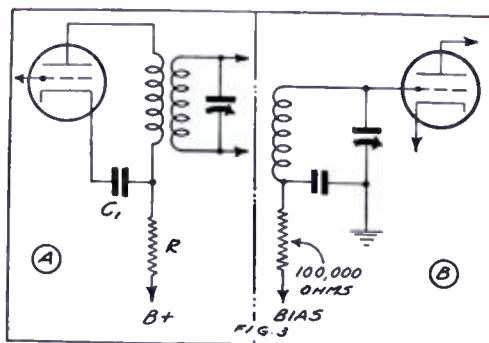

Grid and plate filters, so necessary for efficient short-wave operation.

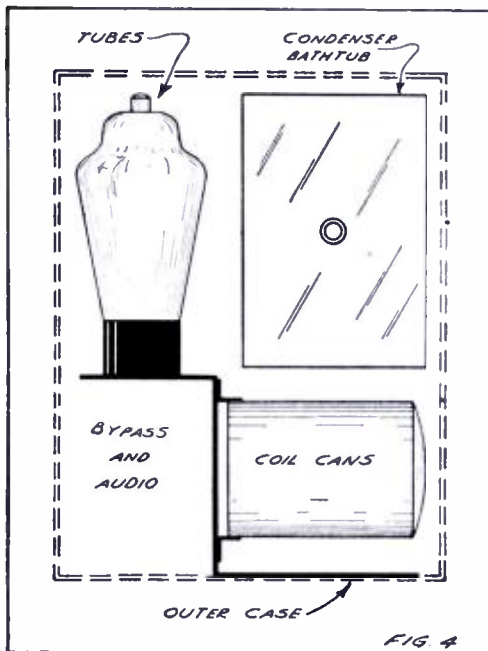

Placement of parts for efficient operation. The leads are short, the shield can is large and well placed. An important point in connection with shielding is that when the source of the field—the coil, in our case—is shielded, the entire effect of the shield may be nullified if it is not properly grounded. The effect of the ground is to fix the potential of the metallic shield, so that it cannot vary and so produce another external field of its own.

Transposed Lead-ins

SOME people who put up noise-reducing antennas using transposed-wire feeders are faced with the problem of making suitable connection between the lead-in, where it terminates at the window and the receiver proper, which may be fifteen or twenty feet away across a room or several rooms. This inside wiring must also be of the non-pickup type if the full benefits of the system are to be realized.

The ideal method is to continue the transposed-wire arrangement right up to the input posts of the receiver. While this is entirely practicable if the receiver is located in a cellar or attic radio "den," it is not so simple if the set is in the living room or some other place where such a conspicuous piece of wiring is obviously undesirable. Ordinary twisted lamp cord, kept as free as possible of radiators, electric wiring and other grounded objects, has been used very successfully. The flexible, metal-sheathed cable known as "BX" is

settled by so simple a thing as slapping a metal sheet under the set, bypassing both sides of the 110 volt line through a .1 non-inductive paper condenser to chassis (use 600 volt sort), or helping some alleged bypass with another, shorter, bypass route. One may find that the antenna lead has been dragged all over the set and brought near most of the wrong things. Fence it off with sheet metal.

Having gotten to the point where extinguishing filament No. 1 causes silence, we may proceed to stage 2, first restoring the filament of No. 1. Manifestly we now have a harder job, as the first stage is again amplifying and the r.f. voltages are correspondingly larger if we start with the same signal. It may be necessary to use a shorter antenna until we have things fairly well tamed, before again using the regular antenna.

The procedure is the same. Having gone through this business we can then restore the second filament circuit and, as a rule, will find that the set has materially improved in performance, especially in cases where its previous tendency was toward noise and a bad image ratio. Oddly enough, some sets will, after such treatment, receive fewer stations! These are sets which are not well enough made or trimmed so that the stages all tune together. As long as there are a lot of stray capacities and other means of coupling, signals contrive to get to the first detector in spite of mistuning of the r.f. stages—with these coupling removed only signals that are legitimately tuned in will arrive. If re-trimming does not improve matters, or the set refuses to stay in trim, you had perhaps better decide if there is anyone whom you dislike badly enough to give the set to.

even better, as the tight covering makes a perfect shield.

If the lead-in must be run a considerable distance through a cellar, the large transposition blocks used for outdoor purposes can be dispensed with and very small blocks, cut out of scrap pieces of thin sheet bakelite, used instead. These need not be more than an inch wide and about two inches long. A half hour's work with a hack saw on an old panel will yield enough blocks for any ordinary inside stretch.

European Listeners Favored

As far as reception of American broadcasting stations in Europe is concerned, the time difference is in the favor of European listeners. Many American stations on the regular broadcast band are heard quite regularly in Great Britain and on the Continent, as there is darkness over the entire path of transmission during our evening hours, when our stations are most active. Of course, the Europeans have to stay up fairly late, but radio fans seem to like it.

Revamping the Old "Super-Wasp"

OWNERS of the once-famous but now obsolete Super-Wasp short-wave receivers can modernize their sets without much trouble, and thereafter enjoy comfortable loudspeaker reception from many foreign stations that now require the use of headphones. When it was placed on the market four years ago, this set was really somewhat ahead of its time, so today, despite tremendous recent advances in set design, many of its features lend themselves very nicely to 1934 technique. A careful revamping job will provide the experimenters with some interesting tool work and also reward them with gratifyingly good radio signals.

The original a.c. Super-Wasp used four tubes and a separate power pack. The receiver proper was wired as shown in Fig. 1. A type 24 screen-grid tube, V1, acted as r.f. amplifier, working into a type 27 detector, V2, with reliable tickler feed-back and condenser control of regeneration by unit C3. This was followed by one resistance-coupled and one transformer-coupled audio stage, both using type 27 tubes, V3 and V4.

Figure 2 shows the new circuit. The r.f. tube V1 is now a 58; the detector V2, a 57; and the audio amplifier has been condensed into a single stage using a type 2A5 output pentode. This combination has a "sock" that must be heard to be appreciated!

Changes Are Easy

The nut-and-bolt construction of the Super-Wasp chassis makes the necessary mechanical changes quite easy. In the left-hand shield compartment, the plug-in coil-tuning condenser combination L1-C1 remains unchanged, but a new six-prong socket with a shield can must replace the old five-prong socket of the 24. The shield must be grounded to the aluminum deck, but at the same time it must also clear the socket soldering lugs. Little piles of washers over the socket mounting screws will fix this little detail. The bias resistor for V1, formerly 450 ohms, must now be 300 ohms, and the useless r.f. chokes-resistors removed from both the screen and plate circuits. The former bypass condensers C10 and C11 are retained.

In the right hand can (detector compartment) the 27 socket is replaced by another six-prong unit and a shield. The grid condenser and leak C5-R3 must be elevated so that they connect between the coil socket and the CAP electrode of the type 57 tube. With both the 58 and the 57, the suppressor grid is tied merely to the cathode. The diagram of the socket connections should be studied carefully.

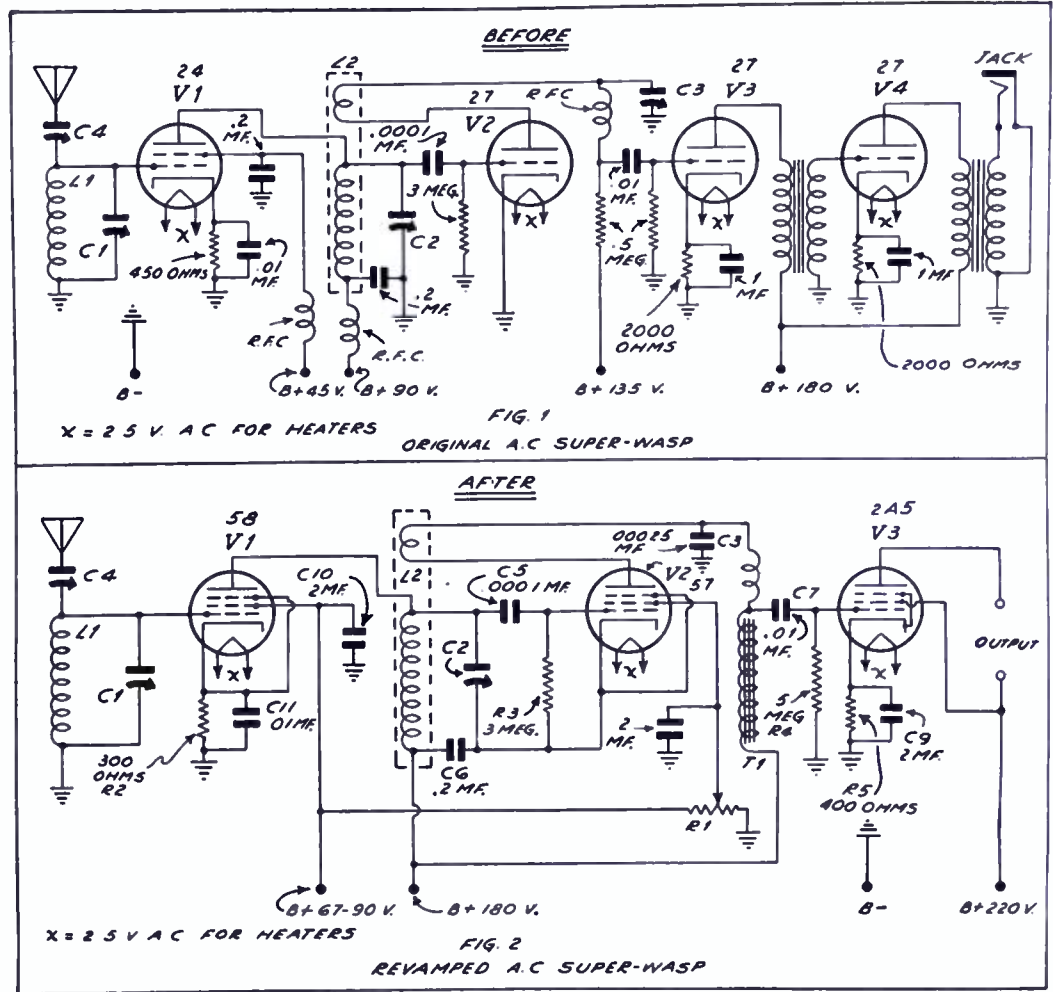

The .00025 mf. variable condenser, C3, mounted on the front panel between the shield cans and formerly used for regeneration control, is eliminated in favor of a 50,000-ohm potentiometer, R1, which now controls regeneration by varying the screen voltage of the 57. The bypass condenser, C8, between the potentiometer arm and ground, must be at least 2 mf. and of good quality. A poor or inadequate condenser at this point will make the regeneration control very noisy, and no worse fault can develop in any short-wave receiver.

The small mica condenser, C3, between one end of the tickler and ground, has an important effect on the regenerative action. The best size is a matter of experiment; usually .0001 or .00025 mf. is about right.

Adjusting the Ticklers

Since the type 57 tube seems to regenerate much more readily than the 27, it may be necessary to remove some of the tickler winding from each detector plug-in coil, L2. Too much tickler makes itself evident in violent, uncontrollable oscillation and possibly terrific howling. With the detector tuning condenser C2 fully meshed, each coil should be adjusted so that the set slides smoothly into regeneration with about 30 volts on the screen. As not many short-wave fans have high-resistance voltmeters, this setting can only be approximated; three-

quarters of the potentiometer movement is about right.

The device represented in Fig. 2 as T1 is supposed to be a high impedance choke coil. There is a special unit, made for the purpose, on the market, but the builder can get practically the same overall results by using the secondary ONLY of the former interstage transformer T1 of Fig. 1. The primary posts are merely left idle. The original Super-Wasp used a 500,000 ohm resistor in the identical position in the plate circuit of the 27, and many modern diagrams show a similar resistor arrangement. However, a choke coil is very much superior, as it permits the plate of the detector tube to receive a respectable plate voltage and at the same time keeps the audio frequency component of the plate current out of the power supply circuit and forces it into the audio amplifier, where it belongs.

The audio output stage is simplicity itself. The old transformer T1 is left in its present position but reconnected as per Fig. 2, and a six-prong socket installed to replace the five-prong socket of V4 of the original receiver. The bias resistor, a new one, is of 400 ohms. The bypass condenser C9 may be the two former 1 mf. units used with the individual 2000-ohm biasing resistors of V3 and V4.

The choice of a suitable output transformer to connect to the two posts marked "output" depends on
(Continued on page 38)

The Worcester CONSTANT BAND-SPREAD SIX

By J. A. Worcester, Jr.

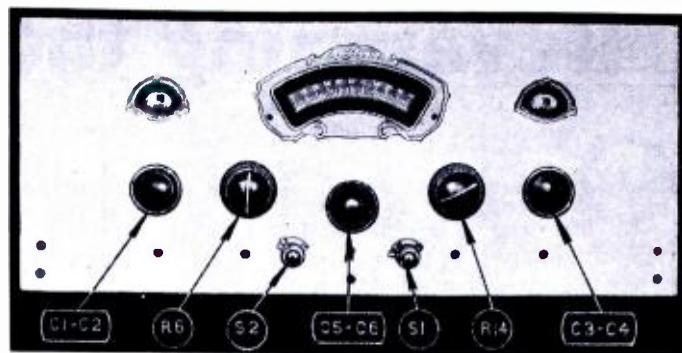

Panel of the Constant Band-Spread Six with the controls marked for convenience.

THE receiver described in this article, aside from incorporating the latest features usually associated with modern short-wave superheterodynes, such as the use of a pentagrid converter, air-tuned intermediate transformers, beat-frequency oscillator and pentode audio output, also includes several important new features which should make this the ideal receiver for the constructor desiring the utmost in performance consistent with the present development of the art. The new features are enumerated and discussed in detail in the following paragraphs.

Constant Band Spread

The average short-wave fan is undoubtedly familiar with the advantages to be derived from band-spread tuning, particularly at the higher frequencies, where the wide frequency range covered by each coil makes satisfactory tuning impossible when employing the tank condensers alone. However, there have been certain inherent objections to the methods of band spreading now commercially used. These objections have limited the effectiveness of band-spreading and are responsible for the fact that few receivers constructed by short-wave enthusiasts incorporate this feature.

Commercial receivers which use bandspread tuning either limit the action to the four amateur bands or, in instances where continuous band-spreading is employed, the frequency range covered by the band-spread capacity varies greatly, depending on the setting of the tank controls and the coil range used. In one representative receiver of this latter class, the frequency range covered by the band-spread capacity varies from about 250 kc. at 9 megacycles to 2000 kc. at 20 mc.; from 150 kc. at 4.8 mc., to 1050 kc. at 10.5 mc.; from 250 kc. at 2.5 mc. to 1500 kc. at 5.5 mc.; and from 100 kc. at 1.1 mc. to 750 kc. at 2.5 mc.

From an inspection of the above data it can be seen that the band-spreading at one extreme of the tank capacity is too slow, necessitating frequency adjustments of the tank capacity; while, at the opposite extreme, the tuning is too fast, defeating to a great extent the object of band-spread tuning.

The system of band-spreading in-

SUMMARY: *This receiver was designed to satisfy the numerous requests from constructors who wanted a superheterodyne that incorporated the constant band-spread idea of Mr. Worcester and the noise-reducing principles outlined in the March, 1934, issue.*

We take pleasure in presenting this receiver, which is one of the best we have had the pleasure of listening to in a long time.

corporated in this receiver eliminates the above objections, as it provides a constant 500 kc. band-spread on all coil ranges except the lowest-frequency coil, covering the 1.2 to 2.5 mc. range, where the band-spread tuning is purposely reduced to about 250 kc. This procedure is desirable, since the frequency range covered by this coil is considerably less than that covered by the other coil ranges.

For a more thorough analysis of the band-spread problem and the mechanics of its solution as employed in this system, the interested reader is referred to the February, 1934, issue of this magazine, which included an article devoted to this problem.

Parallel Operated Pentagrid Converters

The 2A7 pentagrid converter tubes are connected in parallel in the mixer stage. As far as the mixer stage itself is concerned, there are two advantages to be derived from this procedure. In the first place, the internal plate impedance of the first stage is halved, which results in approximately twice the amplification that can be obtained with a single tube. This, of course, assumes that the impedance of the plate tuned circuit is small compared to the internal impedance of the tube, which is the case with present-day r.f. pentodes.

An important result of this increased gain in the first tube is a resulting increase in the signal-to-noise ratio, since it has been found that the above ratio is a function of the gain in the first tube. (See the March, 1934, issues, page 28.—*Tech. Dir.*) This is the reason why an ap-

preciable increase in the signal-to-noise ratio is obtained when a stage of r.f. amplification is incorporated ahead of the mixer stage in a broadcast receiver; approximately three times the gain can be obtained in the r.f. stage than in the mixer. The gain possible in an r.f. stage is greatly reduced on the short waves, however, so that doubling the gain by employing parallel mixer tubes results in a signal-to-noise ratio as good or better than could be obtained if a pre-amplifier stage were incorporated.

Another advantage of employing parallel operated 2A7 tubes in the mixer stage occurs in the oscillator circuit, where the parallel connection makes it much easier to produce oscillations at the higher frequencies. When using a single 2A7 tube, some difficulty of this nature is liable to occur at the higher frequencies, and, in some instances, a triode has had to be connected in parallel with the oscillator elements in order to obtain satisfactory operation.

Dual Volume Control

In this receiver, independent control of the radio-frequency and audio-frequency amplification is provided. The audio-frequency gain control is intended as the normal volume control with the r.f. control left at its mid position for normal use. When additional gain is required on weak signals, the r.f. gain control may be advanced beyond this position; or, in instances where overloading is evident on strong signals, the r.f. gain control may be reduced beyond its normal mid-position. With the advent of the new tubes with their extended plate current cut-off, the danger of overloading when using an audio volume control exclusively is not nearly as pronounced as with the older type tubes. An important advantage of being able to vary the audio gain is the possibility of connecting ear-phones directly in the pentode plate circuit and reducing the a.f. amplification until a satisfactory hum level is produced for this purpose.

The construction of this receiver will be described starting with the r.f. mixer stage and progressing systematically to the audio pentode output.

The chassis is constructed from No. 16 gauge aluminum and meas-

ures 17" x 12" x 1½". The front panel of similar material measures 17" x 7". Mounted on the front panel are the centrally located full-vision dial, which controls the band-spreading condensers, C5 and C6, the two tank controls, the two amplification controls, and the two switches. The left-hand switch breaks the plate supply while the right-hand switch controls the beat-frequency oscillator.

The tank control on the left varies the r.f. input tank condensers C1, C2, while the right-hand control varies the oscillator tank, C3, C4. The r.f. amplification control is on the left, the a.f. control being on the right. The proper location of the various parts can be noted from the photographs. It will be noted that the

dual variable condensers are mounted on aluminum brackets in order to provide room for the tuning units behind the panel. These brackets are 2¼" wide and 3¼" high, and are mounted about 1" behind the front panel.

In order to isolate both sections of the band-spreading tank control, C5-C6, from each other and from ground, some simple alterations have to be made on this dual condenser. Since the common rotor and stator assemblies are conveniently mounted on a heavy Isolantite base, it is a simple matter to unscrew these and disassemble the condenser.

About 1/16" of shaft is then sawed from the center of the common rotor, thus isolating the two rotors. The shafts are then joined together by

slipping a half-inch length of bakelite tubing, having an inside diameter of ¼", over the two shafts. After the condenser is reassembled and the correct spacing of the rotor shafts determined, the two shafts are pinned to the bakelite sleeve by drilling a small hole (No. 60 drill) at each extremity of the sleeve and about ¼" into the brass shaft. A piece of stiff wire of the proper size is then driven into each hole and cut off flush with the sleeve. It is, of course, obvious that the two rotors should be lined up before drilling the holes.

The condenser is insulated from the bracket by means of insulating washers and from the dial shaft by means of a small length of bakelite tubing similar to that previously

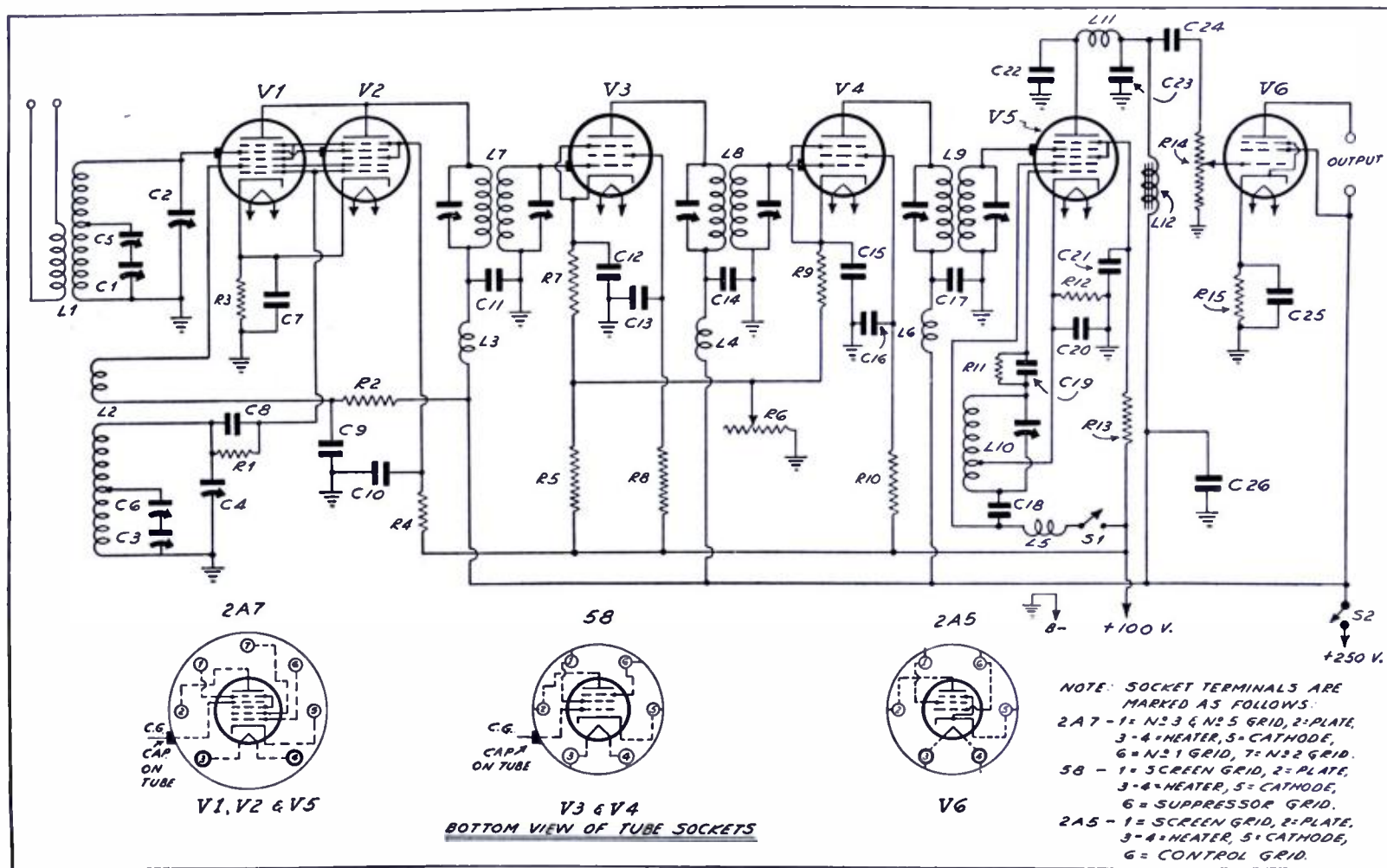

- L1—Antenna inductance, see text. Wound on Hammarlund Isolantite six-prong coil forms, CF-6. Four required.
- L2—Oscillator inductance, see text. Wound on Hammarlund Isolantite five-prong coil forms, CF-5. Four required.
- L3, L4, L5, L6—Hammarlund Isolantite 8 mh. r.f. chokes, type CH-8.
- L7, L8, L9—Hammarlund air tuned i.f. transformers, 465 kc., type ATT-465.
- L10—Hammarlund 465 kc. beat oscillator, type ATO.
- L11—Hammarlund 85 mh. r.f. choke, type RFC-85.
- L12—Thordarson 3:1 audio transformer, used as choke by connecting B plus to ground side of secondary.
- C1-C2, C3-C4—Two Hammarlund dual midget condensers, 140 mmf. per section, type MCD-140-M.
- C5-C6—Hammarlund MCD-140-M Dual condenser with alterations as explained in text.
- C7, C9, C11—Aerovox .01 mf. cartridge condensers.

- C8—Aerovox .0001 mf. mica condenser.
- C10, C14—Aerovox .05 mf. cartridge condensers.
- C12-C13, C15-C16, C17-C21—Blan .05 mf. dual paper bypass condensers (labeled .05-.025 mf.).
- C18, C22, C23—Aerovox .0005 mf. mica condenser.
- C19—Included in Hammarlund ATO transformer.
- C20—Aerovox .5 mf. tubular bypass condenser.
- C24—Aerovox .01 mf. tubular condenser.
- C25—Aerovox 20 mf. 25-volt dry electrolytic condenser.
- R1—Aerovox 50,000-ohm resistor.
- R2—Aerovox 10,000-ohm resistor.
- R3—Lynch 150-ohm resistor.
- R4, R5, R8, R10, R13—Aerovox 25,000-ohm resistors.
- R6—Electrad 5,000-ohm potentiometer.
- R7, R9—Lynch 400-ohm resistors.
- R11—Included in Hammarlund ATO transformer.

- R12, R15—Lynch 500-ohm resistors.
- R14—Electrad 500,000-ohm potentiometer.
- 1 Blan chassis—17" x 12" x 1½" aluminum.
- 1 Blan panel—17" x 7" aluminum.
- \$1, \$2—Yaxley No. 10 midget switches.
- 1—Crowe No. 48 tuning unit with No. 8506 escutcheon.
- 2—Crowe No. 45 tuning units with No. 9561 escutcheon.
- 1—Eby triple binding post assembly.
- 1—Eby twin speaker jack.
- 3—Eby small size seven-prong wafer sockets.
- 3—Eby six-prong wafer sockets.
- 1—Hammarlund Isolantite five-prong socket type S-5.
- 1—Hammarlund Isolantite six-prong socket type S-6.
- 3—type 2A7 tubes.
- 2—type 58 tubes.
- 1—type 2A5 tube.
- 5 ft. five-conductor battery cable.
- 5—Hammarlund type TS-50 tube shields.

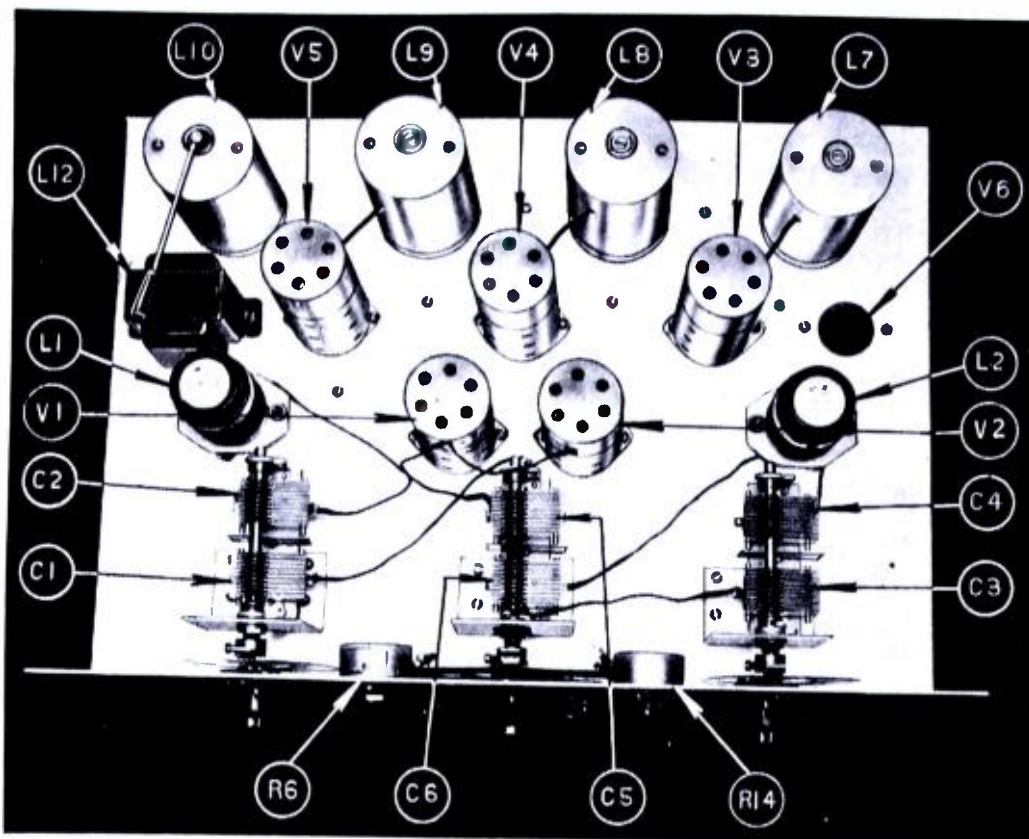

Top view of the chassis of the receiver. Note the brackets for mounting the tuning condensers and the insulated coupling for C5-C6 (see text).

used, having an inside diameter of $\frac{1}{4}$ " and an outside diameter of about $\frac{3}{8}$ ". This tubing should be slit lengthwise so that the set-screw will effectively secure the shaft. In view of the above, the mounting hole in this dial should be $\frac{3}{8}$ ", while the other two dials should have $\frac{1}{4}$ " mounting holes. When this work is completed, the assembly should be given a continuity test to make sure that both rotors are isolated from ground and from each other.

Construction Details

As will be noted from the photographs, the two coil sockets are mounted above the chassis. In order to prevent placing the oscillator coil in the input circuit and vice versa, the input coils are wound on six-prong coil forms, while five-prong forms are used for the oscillator coils. The complete winding data for these coils are included in Table No. 1. When wiring this portion of the receiver, the high-frequency leads joining the variable condensers and leading to the control grid and coil sockets are run above the chassis, as can be seen from the photographs. This may not enhance the appearance of the receiver, but does result in an appreciable improvement in performance.

The wiring of the intermediate-frequency amplifier should not present any special difficulties. The important point is to mount the various bypass condensers as close as possible to the points they are bypassing. The same procedure should be followed in wiring the r.f. chokes and decoupling resistors.

The beat-frequency oscillator unit, however, requires some comment.

Unfortunately, the transformer was designed for use with an additional tube as an electron-coupled oscillator. In order to adapt this transformer to the 2A7 pentagrid converter, the following changes are made. The aluminum cover is removed and the shielded grid wire cut off where it joins the grid condenser. Another wire is then soldered in its place which is brought out through the bottom of the transformer. The external portion of this wire is shielded and the shield grounded. When connecting this unit, the bottom lead which is normally grounded is connected to the anode grid through the condenser C18. Before the beat-frequency transformer is reassembled, a strip of light cardboard or similar material should be laid alongside the brass frame to prevent it from making contact with the aluminum cover.

The wiring of the audio-frequency portion of the receiver is entirely conventional and requires no special

comment. It might be well to point out, however, that it is necessary to observe the polarity of the condenser, C25. The proper connection is to connect the red cap to the cathode.

When putting the receiver into operation, it will be noted that the input is designed to take a doublet type of antenna. If an ordinary antenna is used, one of the doublet connections should be connected to the ground terminal. Power connections are made to a five-conductor cable which is connected directly to the required points.

When tuning the receiver, the tank controls are turned in unison until the receiver is tuned to the desired band. The actual tuning process is then carried out by the band-spreading control. When searching for the desired band, the use of the beat-frequency oscillator will be found helpful. If the reception of modulated signals is desired, the beat oscillator is turned off after the carrier has been tuned in.

Tested by Editors

The editors of SHORT WAVE RADIO put Mr. Worcester's Constant Band-Spread Six through a number of tests and are glad to report that its performance was highly satisfactory in every way. The band spreading feature certainly does make for convenience in operation, and at the same time the set retains the high degree of selectivity for which superheterodynes are noted.

The entire trick in tuning this receiver is to set the tank condensers C1-C2 and C3-C4 for any desired portion of each coil's tuning range and then to do the main tuning with the band spread condenser C5-C6, which is controlled by the large vernier dial in the center of the panel. It is a pleasure to see how comfortably this receiver separates the jumbled mass of stations on the 49-meter band, in particular. In fact, the set operates very much like a regular broadcast receiver.

If the coil data as given by Mr. Worcester are followed accurately, the tank condensers C1-C2 and C3-C4 will track within a few degrees. After the owner has oper-

TABLE NO. 1 WINDING DETAILS OF DETECTOR COIL

Frequency Range in Mc.	Primary Winding		Secondary Winding		
	No. Turns	Wire Size	No. Turns	Wire Size	Tap At
10-20	5.0	No. 30 D.S.C.	7.3*	No. 22 En.	3
5-10	7.0	No. 30 D.S.C.	14.0*	No. 22 En.	9
2.5-5	9.0	No. 30 D.S.C.	27.0*	No. 22 En.	27
1.2-2.5	10.0	No. 30 D.S.C.	50.0**	No. 24 D.S.C.	50

WINDING DETAILS OF OSCILLATOR COIL

Frequency Range in Mc.	Tickler Winding		Secondary Winding		
	No. Turns	Wire Size	No. Turns	Wire Size	Tap At
10-20	7	No. 30 D.S.C.	7*	No. 22 En.	3.0
5-10	9	No. 30 D.S.C.	12.5*	No. 22 En.	8.0
2.5-5	14	No. 30 D.S.C.	21.5*	No. 22 En.	21.5
1.2-2.5	15	No. 30 D.S.C.	43**	No. 22 D.S.C.	34.0

*Turns spaced to occupy $1\frac{1}{2}$ ".

**Turns not spaced.

ated the set for a few days, he will be able to log the dials according to stations of known frequency.

The Constant Band Spread Six is truly an all-purpose receiver, being just as suitable for amateur communication purposes as for shortwave broadcast reception. With the beat frequency oscillator turned on, code stations beyond all count will pour in.

As a matter of fact, the local beat-frequency oscillator controlled by switch S1 is just as useful for phone reception as for code reception. It makes the location of carrier waves quick and easy. Furthermore, if the oscillator is left on for phone reception and the handle on the oscillator coil, L10, is adjusted very carefully for zero beat, signals will be decidedly louder than with the oscillator off, although the quality will suffer considerably. For the reception of weak stations, this is a stunt worth remembering.

Some More Notes

The switch S2 should be turned off when coils are being changed. This will prevent uncomfortable thumping in the loudspeaker. It is also useful when the operator wants to turn the set off for a moment without cooling the tubes.

No power supply unit is shown in the article, as any standard pack using a type 80 tube will be found quite satisfactory. For filament supply, the power transformer should have a 2½-volt secondary. The high-voltage end should be capable of furnishing 250 volts on full load. The pack should contain a full filter system consisting of two filter chokes and two or three filter condensers and should incorporate its own output bleeder resistor.

The receiver chassis itself does not contain an output transformer, as this invariably is mounted directly on the frame of all standard dynamic loudspeakers. Of course, the transformer should have a primary that matches the plate impedance of the 2A5 output tube. Field current for the speaker may be supplied from a separate power pack, or the field winding may readily replace one of the filter chokes in the power supply unit. The speaker may be 5, 6, or 8 inches in diameter, depending on how much volume the builder wants. For best tone quality the speaker should, of course, be mounted on some sort of a baffle. This sounds like some more obvious advice, but many short-wave fans use dynamic speakers without baffles and then wonder why voice and music sound unnatural. A three- or four-foot baffle makes a very considerable difference in overall results. If space in the radio den is limited, the speaker can be mounted in a small midget set cabinet. If there is plenty of space available, any flat board or piece of celotex will be found effective. The top of an old bridge table makes an excellent baffle.

Panel and Chassis

The panel and chassis construction employed by Mr. Worcester is simple and logical. If the builder does not want to invest in an entirely new aluminum chassis, he undoubtedly will be able to make use of an existing chassis or receiver deck providing it is large enough to accommodate the various parts. Mr. Worcester spaced everything comfortably for ease in construction and wiring, but any experienced constructor will be able to close up

the parts a little without affecting the operation of the set to any great extent.

The coil specifications as given represent considerable experimental work, and hold only if the specified tuning condensers are employed. Condensers of different size or make are not likely to cover the ranges as specified.

Do not be confused by the number of connections to the pentagrid converter tubes. These look very complicated, but when you actually wire the set and trace the socket prongs as shown in the schematic diagram, you will experience very little trouble.

Some Pointers

The theory outlined by Mr. Worcester is quite sound, as evidenced by the excellent performance of the receiver. It should be noted that no pre-selector is used; the mixer is composed of two tubes in parallel.

The use of two tubes in parallel is equivalent to the addition of another tuned r.f. stage; furthermore, the high gain obtained permits of comparative noise-free reception, as mentioned by the author. This is probably the first short-wave receiver that uses parallel amplifier tubes in the mixer stage.

Constant band-spreading is a feature that has not been given sufficient thought prior to this circuit, which, by the way, is now in the process of being patented by Mr. Worcester. Not only is the usual band-spreading circuit non-uniform over a single band, but varies considerably from band to band. The Constant Band-Spread system is uniform over each band and for all bands. No doubt, this receiver is one of the best that can be built.

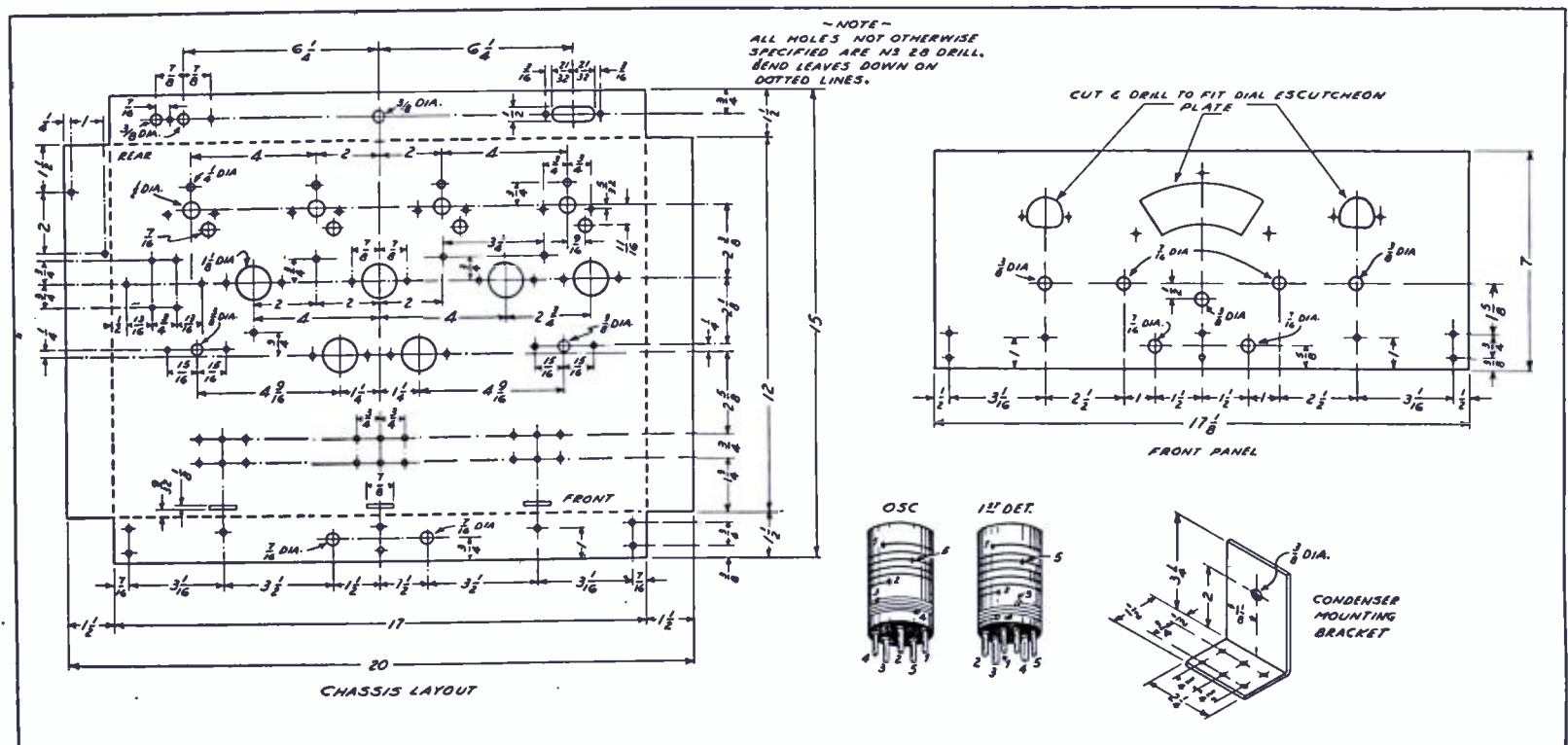

Mechanical details of the chassis, panel, coils and condenser mounting brackets.

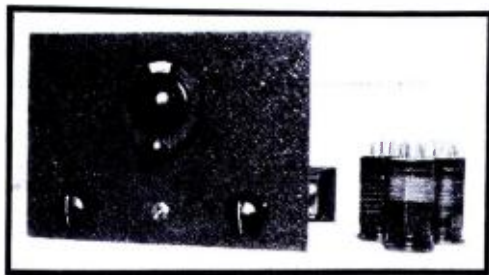

Panel view of the "Trophy Winner."

MOST of the simple and low priced short-wave receivers that have been brought out recently for "DX" enthusiasts who want to hear foreign stations are of the battery operated type, and, therefore, do not particularly appeal to people who have grown accustomed to the convenience, reliability and economy of house-current operation. These sets fill a definite need, but radio listeners who have not bothered with batteries for years would much prefer to start in the interesting short-wave "game" with small a. c. sets.

To fulfill this requirement and to get these people exploring the busy short-wave channels, the writer has designed a simple but effective a. c. short-wave receiver that uses the latest tubes in a dependable, hum-free circuit, and that costs very little more than the average battery model complete with all its necessary A, B and C batteries. The powerful a. c. tubes, of the pentode type, provide comfortable loudspeaker results on many European and South American stations, and, atmospheric conditions permitting, even on Australian and New Zealand stations. With a pair of earphones plugged into the output posts, the listener has practically the entire world at his finger tips.

No Dead Spots

This new receiver, called the Trutest "Trophy Winner," uses a type 58 tube, V1, as an untuned r.f. amplifier (completely eliminating the annoying "dead spots" common with straight regenerative sets), a type 57 as a regenerative detector, with a regeneration control that does not disturb the "logging" of the dial, and a type 2A5 pentode as the audio amplifier. The entire short-wave region from 14 to 200 meters is covered by a set of four plug-in coils, which are easily and quickly interchanged. The parts for the receiver proper are mounted on a rigid, electrically welded steel chassis, finished in spot-proof crystalline black and completely drilled and prepared for easy home assembly. The set is available in kit form, and can be assembled and wired in a couple of evenings with the aid of only a screwdriver, pliers and soldering iron.

The front panel measures only 7 x 10 inches, and the set overall is 8½ inches deep. On the front panel are a vernier tuning dial, the 110-

The "Trophy Winner"

An effective 3-tube set that is all a. c. operated.

By Frank Lester*

volt line switch, SW, the regeneration control, R5, and either condenser C1 or C2, as described later.

All filament, plate and grid voltages are supplied by a separate power pack, built up on a steel chassis measuring 10¼ x 6 x 1¾ inches, and matching the receiver in finish. This is a full-grown pack, complete with shielded power transformer, two individual filter choke coils, and three sections of filter condensers. No attempt was made to cheapen the power unit by eliminating one filter section, as is done in some sets. It was felt that unless the receiver were absolutely quiet, even with earphones, the people who built it would never really enjoy good short-wave reception.

Connection between the receiver

and the pack is made by means of a flexible cable attached to the former and terminating in a plug that matches a socket on the pack's chassis. This flexible arrangement allows the use of the power unit for other receivers or purposes, and will be greatly appreciated by the set owner who later gets bitten by the experimental bug.

The cable has six connections: two for filament current, two for plate current, and two for the 110-volt circuit. The on-off switch for power pack is located right on the front panel of the receiver. Actually, there are eight wires in the cable, but four of them are paired to form the equivalent of two heavy conductors for the filament current.

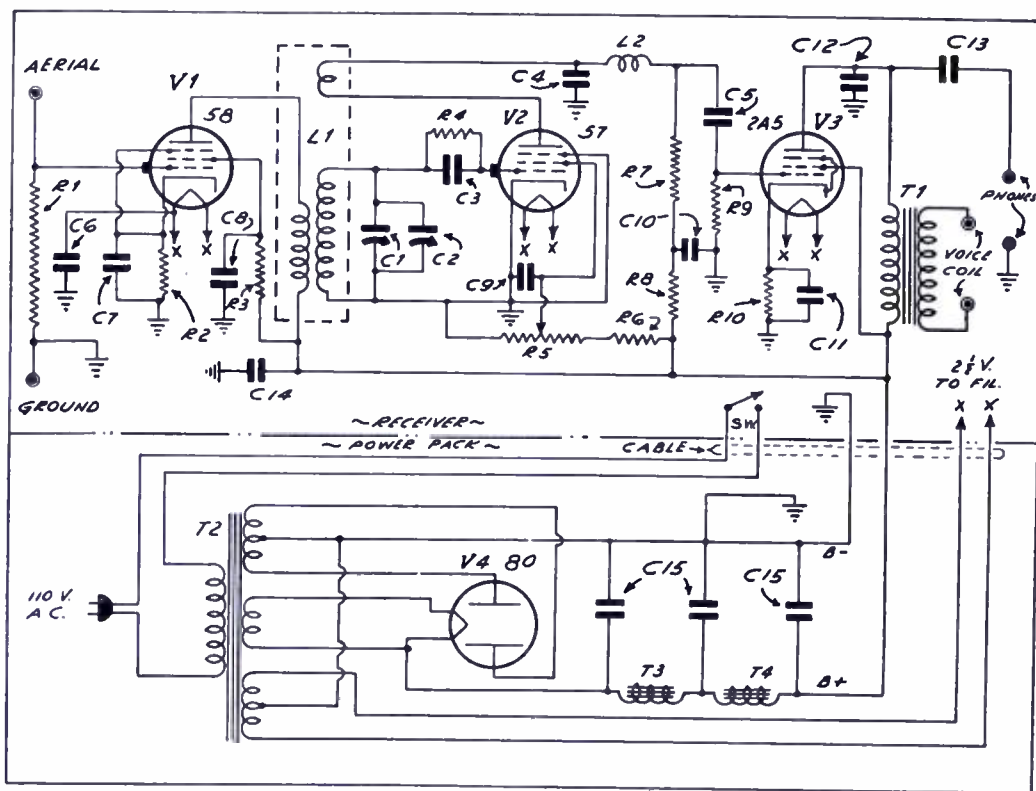

Circuit Diagram of the "Trophy Winner."

- L1—Set of three-winding plug-in coils, 14-200 meters.
- L2—8 mh. r.f. choke coil.
- C1—.00014 mf. variable condenser.
- C2—.00002 mf. variable condenser.
- C3—.0001 mf. grid condenser.
- C4—.00025 mf. condenser.
- C5, C6, C7—.1 mf. condensers.
- C8, C9, C14—.5 mf. condensers.
- C10—.25 mf. condenser.
- C11—10 mf. condenser.
- C12—.001 mf. condenser.
- C13—.25 mf. condenser.
- R1—100,000-ohm resistor.
- R2—3000-ohm resistor.
- R3—75,000-ohm resistor.
- R4—5-megohm grid leak.
- R5—50,000-ohm potentiometer.
- R6—50,000-ohm resistor.
- R7—100,000-ohm resistor.
- R8—50,000-ohm resistor.
- R9—500,000-ohm resistor.
- R10—500-ohm resistor.

- SW—110-volt line switch.
- T1—Output transformer.
- V1—type 58 tube.
- V2—type 57 tube.
- V3—type 2A5 tube.

Mechanical parts include: welded steel chassis, black crystalline finish; four six-prong sockets for the tubes and the plug-in coils; vernier dial for the tuning condenser; double binding-post strip; two tip-jack strips; eight-wire cable and six-prong plug; and all necessary hardware, wire and solder for connections.

Parts for Power Pack

- T2—power transformer.
 - T3, T4—filter chokes.
 - C15—three-section electrolytic filter condenser, 8 mf. each.
 - V4—type 80 tube.
- Mechanical parts include: welded steel chassis, black crystalline finish; four-prong socket for V4 and six-prong socket for connector plug; and all necessary hardware, wire, etc.

* Engineer, Wholesale Radio Service Co., Inc.

Choice of Condenser Connections

A novel feature of the "Trophy Winner" is the manner of mounting the tuning condensers so as to permit either continuous band spreading or regular tuning coverage. Two tuning condensers are supplied: C1, of .00014 mf. capacity, and C2, of .00002 mf. If band spreading is desired (and this is very convenient), the smaller condenser C2 is mounted in the center of the panel and controlled by the vernier dial. The other condenser is placed in the lower left corner of the panel, and acts as a "tank" condenser. The later is set roughly to any particular frequency range, and the main tuning then accomplished with the vernier dial. For general coverage, C1 is mounted behind the dial and C2 in the left corner; C2 then acts as a "trimmer" on C1, being useful mainly on the longer waves, that is, from about 75 meters up to 200. The owner of the set can try either combination and then switch to the other, the change taking only about five minutes. Some people like band spreading, others don't.

An output transformer T1 is included in the receiver. This has a low impedance secondary for direct connection to the voice coil of a small dynamic loudspeaker, which may conveniently be of the permanent magnet type. A speaker with built-in field supply and intended especially for the "Trophy Winner" is available. Earphones or a magnetic speaker are connected to another pair of output posts, the primary of the output transformer in this case acting as a choke coil. The blocking condenser C13 keeps the high plate voltage of the 2A5 out of the phone or speaker windings.

The plug-in coils used with this receiver are of the three-winding type. The primary is interwound with the secondary but altogether insulated from it; thus there is no possibility of damage to the detector tube or circuit caused by the high plate voltage of V1. Regeneration is controlled by the potentiometer R5, which is smooth and quiet. The type 57 tube is an excellent detector, and slides in and out of regeneration with that gratifying ease so essential to successful short-wave tuning.

There is nothing tricky to the operation of the "Trophy Winner."

COIL WINDING DATA

Wave Band (meters)	Secondary		Primary No. Turns (s.c.c.)	Tickler No. Turns (s.c.c.)
	No. Turns (enam.)	Winding Length		
14—36	5—No. 18	1- $\frac{1}{8}$ "	5—No. 26	3—No. 26
34—65	15—No. 18	1- $\frac{1}{2}$ "	9—No. 26	3—No. 26
62—115	29—No. 20	1- $\frac{1}{2}$ "	12—No. 26	4—No. 26
110—200	49—No. 22	1- $\frac{3}{4}$ "	22—No. 26	5—No. 26

The coil forms are 1 $\frac{1}{2}$ " in diameter and 2 $\frac{7}{8}$ " long, and have six prongs.

The set will work with any ordinary aerial and ground, and may even be hooked to the same antenna used with the family broadcast receiver. Only two controls are used at a time—the vernier dial and the regeneration knob. The presence of a station is quickly indicated by a whistle, which disappears as the regeneration control is backed down carefully.

The four plug-in coils supplied with the receiver split the short-wave bands into convenient quarters. The first coil tunes from 14 to 36 meters, and is most useful during the morning and afternoon. On it will be found the European 25-meter stations, which come through with good strength, until sundown. The second coil covers 34-65 meters, and takes in the very active 49-meter night-time channel, which is alive with European, African, Central and South American, and Canadian programs. The third coil takes in 62-115 meters, and will bring in hundreds of amateur stations on 75 meters. The fourth and largest coil, 110-200 meters, is popularly called the police coil because it covers the police radio alarm stations. The owner of the "Trophy Winner" will never have a dull moment!

2. List of Coast Stations and Ship Stations—4.35 Swiss gold francs, including postage. This list is reissued every six months with no supplements.

3. List of Aeronautical Stations and Aircraft Stations—4.15 Swiss gold francs, including postage. This list is reissued every six months without supplements between editions.

4. List of Stations Performing Special Services—5.50 Swiss gold francs, including postage and supplements which are issued every 3 months.

5. List of Broadcasting Stations—3.70 Swiss gold francs, including postage and supplements which are issued every 6 months.

6. List of call letters of Fixed, Land and Mobile stations—7.50 Swiss gold francs, including postage and monthly supplements.

Remittance should be made by international money order to the Bureau of the International Telecommunication Union, Berne, Switzerland.

The revised edition of the Rules and Regulations of the Federal Radio Commission is now ready. Copies cost 30 cents each and must be ordered from the Superintendent of Documents, Government Printing Office, Washington, D. C. Remit by post office money order; do not send stamps.

International Station Lists Now Available

THE following publications of interest to radio listeners are available from the Bureau of the International Telecommunications Union, Berne, Switzerland:

1. List of Frequencies—40 Swiss gold francs, including supplements and postage.

Use for the 48

The 48 has a high-emission cathode which can be used to supply more plate and screen current than is generally demanded of the tube as an amplifier. It therefore finds application for use with current-operated devices such as relays.

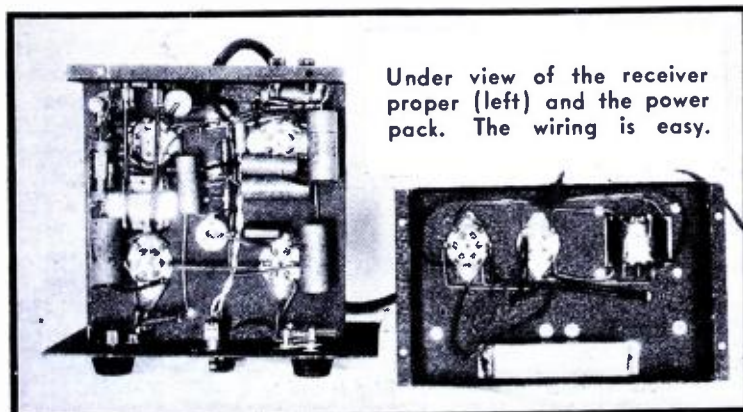

Under view of the receiver proper (left) and the power pack. The wiring is easy.

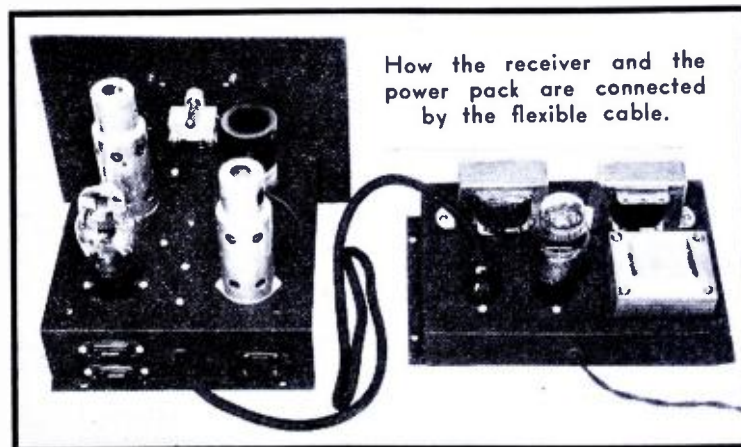

How the receiver and the power pack are connected by the flexible cable.

A Coffee-Can Frequency Meter for the S. W. Listener

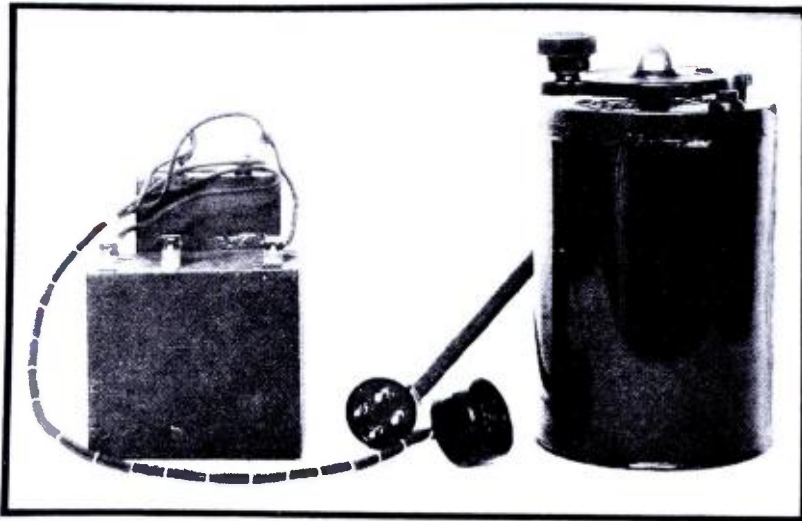

SUMMARY: Here is an oscillator, built in a coffee can, that really percolates. It was designed for the listener who needs a good instrument, but who cannot afford to outlay a great deal of cash. Calibration data and complete construction details are included. The cost? It all depends upon the kind of coffee you drink and your supply of odds and ends. It's a stable instrument, too, and may be relied upon.

PERCOLATORS have long been known for their ability to deliver good, clean coffee, the kind of coffee that keeps you awake at night while you are on the hunt for that elusive foreign station; but I doubt very much whether the roasters of the bean realize that their containers make excellent shields for short-wave oscillators. A simple, accurate frequency meter has been in demand for many a moon, but the cost of the complete shielding required usually amounts to more than the cost of the parts themselves. With this view in mind, the writer developed the beautifully simple oscillator illustrated herewith.

The schematic circuit of Fig. 1 tells the story. The oscillator is of the "sure fire" type—it has no tickler of the usual variety that always seems to be connected up backwards; furthermore the filament is connected to a tap on the coil—not to B—as in the usual hookup—and so has some of the excellent properties of the electron-coupled oscillator without being made complex by the somewhat confusing connections of the screen grid. The A supply connects directly to the filament without regard to polarity; the B supply is just a small 45-volt B battery.

A 100-ohm resistor, R2, is con-

By Louis Martin

nected directly across the filament of the tube; the center tap of this resistor connects to the tap on the coil. The purpose of this resistor is to place the potential of the filament above ground so as to secure freedom from the frequency drift so common in the more usual oscillator. Although it might be well to bypass this resistor, the cost of suitable condensers (one is needed from each end to the center tap) is unwarranted. It is of utmost importance, though, that C2 be a good mica condenser, otherwise the circuit will never oscillate. The conventional grid leak and grid condenser, tuning condenser, coil, and pick-up coil complete the whole business. Simple, eh, what?

Assembling the Oscillator

First, procure an Ehlers or Chase and Sanborn coffee can, which has, of course, been emptied of its contents. These cans are about four inches in diameter and six inches long. Remove the cover and set the can itself aside, for every part used in the oscillator is mounted on the cover only. In the center of the cover drill a hole large enough to take the shaft of the tuning con-

denser. This condenser should have a maximum capacity of 100 mmf. and be as small as possible. Mount the condenser.

Next cut four pieces of brass tubing, $\frac{1}{4}$ inch in diameter and 2 inches long, as shown in A of Fig. 2. File down the heads of four No. 6/32 machine screws so that the head ends of the screws may be forced into the hollow part of the tubing. Fill the remaining crevices with solder and you have the equivalent of a threaded brass rod. Of course, if you are fortunate enough to own a stock and die, then this little kink may be dispensed with entirely.

Now, insert the threaded ends of the rods into the mounting holes of a four- and a five-prong socket and tighten with the usual lock washers and nuts. The cover is then turned bottom up, the condenser turned until the plates are all the way out, and the sockets placed until the clearance between the tube and coil and can side is about one-half inch. In determining the clearance, place the tube and coil in their respective sockets (the coil takes the five-prong socket) and gauge by means of a straight edge. A hole is then drilled through the cover to house the antenna tip jack, and the oscillator is ready for wiring.

- C1—100 mmf. variable condenser, Hammarlund.
- C2—.005 mf. mica condenser Cornell-Dubilier.
- C3—.000125 mf. mica condenser, Cornell-Dubilier.
- R1—100,000-ohm, $\frac{1}{2}$ -watt resistor, Lynch.
- R2—100-ohm resistor, center tapped.
- R3—15-ohm pigtail resistor, see text.
- One set of coils, see text. Alden or equivalent.
- One four-prong socket, wafer type, Eby.
- One five-prong socket, wafer type, Eby.
- One antenna tip jack.
- One type 30 tube, Raytheon.
- One coffee can, see text.
- One four-prong male-female connector, Blan.
- One type B midget dial, National.
- Eight inches of $\frac{1}{4}$ -inch brass tubing.
- Several feet of four-wire battery cable.
- Bus bar, solder, etc.

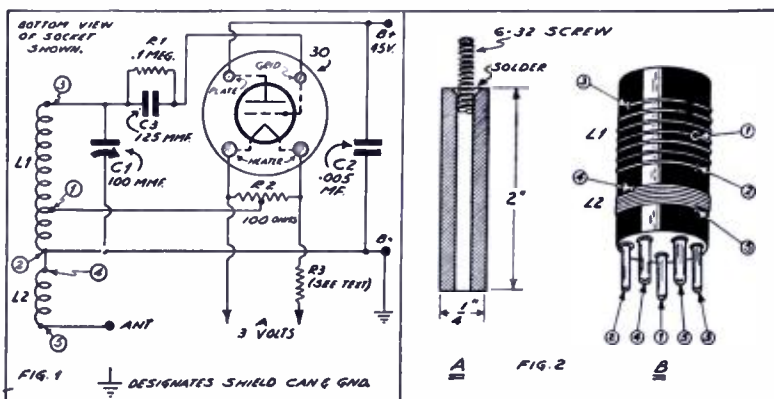

Left: schematic circuit of the coffee can oscillator. Right: mounting bracket and coil-winding data.

The circuit uses a three-element tube connected as a sort of electron-coupled oscillator. The values of parts are conventional. R2 is a fixed resistor; see the text for the value of R3.

Be sure to use bus bar throughout. Too many oscillators have failed simply because wobbly, uncertain wiring never remains in the same place any length of time. Every time a grid or a plate wire changes its position with respect to the rest of the wiring, the calibration of the oscillator changes.

Connect the two nearest nuts of the two socket mounting screws together with a stiff piece of bus bar. This will keep the sockets rigid and prevent the cover from losing its shape. Mount the grid leak and grid condensers, and the center-tapped resistor across the filament by means of the wiring itself. Then connect the tuning condenser and the bypass condensers, C2, to their corresponding destinations. One wire from the center tap of the resistor to the coil socket and another from the antenna tip jack to the pick-up coil complete the wiring. The only thing that remains is the battery cable.

A four-wire cable about a foot long is used. One end of the cable connects directly to the filament, plate and can of the oscillator unit, and the other to the four-prong male connector. The female section of the connector plug goes to the batteries. This method of connection has several distinct advantages: first, it obviates the necessity for a filament switch, which would be difficult to mount on the "panel"; second, it permits the batteries to be located in an inconspicuous location, thus making the oscillator an asset, as far as appearance goes, rather than a liability; and third, if the batteries were mounted in a separate can which plugged into the oscillator can (a thought which occurred to the writer), then the composite would be far too unwieldy for ordinary use. The plug and cable idea solves the problem to perfection. The writer used a shielded cable, the shield being soldered to the top of the can for support.

Coil Data

Only two coils are required to cover the entire short-wave bands. The first coil tunes from about 1800 kc. to about 3700 kc., and its harmonics could be picked up at 30,000 kc. (10 meters). The only difficulty with using one coil and its harmonics is that tuning becomes extremely sharp on the higher frequencies, and the oscillator is worthless. However, by building a smaller coil, which has a much higher fundamental frequency, tuning becomes relatively simple and the cost is reduced. This idea is shown in the following table of harmonics:

COIL NO. 1

Fundamental frequency .. 1800 kc.
 Second harmonic 3600 kc.
 Third harmonic 5400 kc.
 Fourth harmonic 7200 kc.
 Fifth harmonic 9000 kc.
 Sixth harmonic 10,800 kc.

Calibration curves for the two coils used in the oscillator. The method of obtaining them is discussed in the article. With these two curves, the entire short-wave band can be covered.

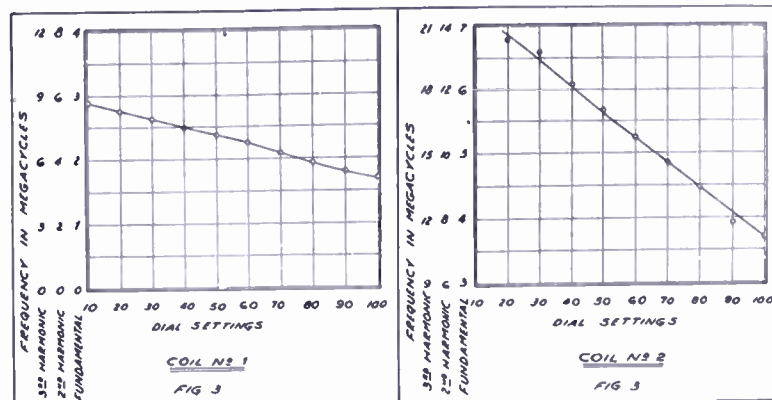

COIL NO. 2

Fundamental frequency... 4000 kc.
 Second harmonic 8000 kc.
 Third harmonic 12000 kc.
 Fourth harmonic 16000 kc.

Note that with the second coil, the frequency of 12,800 kc. is reached at only 3.2 times the fundamental; while with the No. 1 coil, the same frequency is reached at 6 times the fundamental. All this complex arithmetic merely shows that with the second coil there is only about half the crowding that is obtained with the first.

Both coils are wound on standard five-prong forms, 1 1/4 inches in diameter and 2 inches long. Coil No. 1 consists of 52 turns of No. 26 s.c.c. wire tapped at 17 1/4 turns from the bottom. The pickup winding has 10 turns of No. 28 s.c.c. wire spaced 1/8 inch from the oscillator coil. Both coils are close wound.

Coil No. 2 consists of 22 turns of No. 24 s.c.c. wire tapped at 7 1/4 turns from the bottom. The pickup winding consists of 7 turns of No. 28 s.c.c. wire spaced 1/8 inch from the bottom of the oscillator coil. Here, again, both coils are close wound. A diagram showing the connections to the pins of the coil forms is shown in B of Fig. 2.

The Batteries

Little need be said about the batteries themselves. The B unit is a standard small size 45-volt affair of the type procurable in any radio or well-stocked hardware store. The A battery may be one cell of a 6-volt storage battery, two No. 6 dry cells in series, or one of the small 3-volt batteries, such as shown in one of the photographs and now available in all stores. If a 2-volt supply is available, merely connect its terminals directly to the filament of the tube; if only 3 volts is handy, then a 15-ohm fixed resistor *must* be connected in series with one of the A leads to cut the voltage at the filament to 2 volts. A pigtail-type resistor, which mounts neatly on the A battery proper, is excellent for the purpose. This is the resistor labeled R3 in the diagram of connections.

Calibrating the Meter

In spite of its simplicity, this little oscillator is extremely accurate and rugged. However, it is no more accurate than the accuracy with

which it is calibrated—it never can be. For this reason, the calibration is just as important as the construction, and the prospective user must follow instructions carefully.

First, calibrate your present short-wave receiver. This may be done easily by sitting down, lighting your pipe, and logging well-known stations on as many points as possible, say, every fifteen degrees on the dial (a 0-100 graduated dial). This part of the job takes time and patience, but is the most important part of the whole business. This need be done for only the lowest frequency band (highest wavelength) of your receiver. When you are finished, plot a curve, labeling the vertical lines in frequency and the horizontal lines in dial settings.

Now, turn on the oscillator by connecting the male and female of the plug and turn the condenser dial to 100. Tune your receiver until you hear the oscillator. It should be noted at this point that the oscillator is not modulated—a musical note will not be heard. Modulation was eliminated because tuning becomes far too broad to be of any use when the oscillator is modulated. What do you hear, though, is the familiar "swish" of a carrier. Continue to tune the receiver to a higher and higher wavelength until the oscillator can no longer be heard. When making these tests, couple the lead from the antenna of the oscillator

(Continued on page 38)

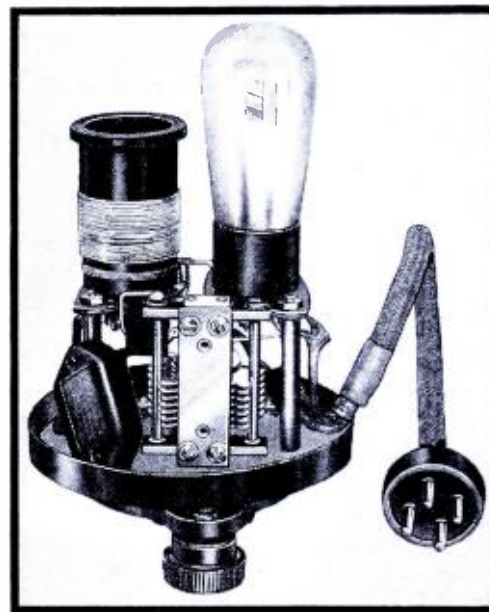

All the parts are mounted on the cover of the can. The grid-leak and grid-condenser are mounted behind the tuning condenser.

The "DX-2"

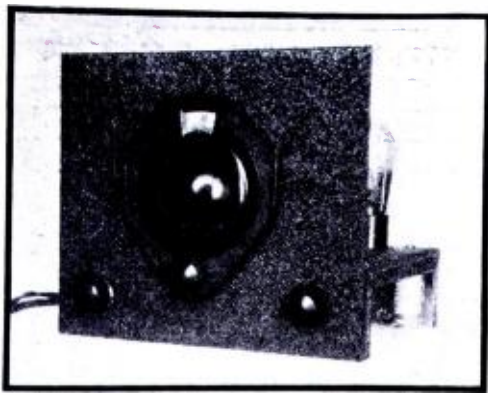

Panel and rear views of the "DX-2" described by the author. It is really a three-tube receiver of good design.



THE short-wave receiver described in this article should prove to be of considerable interest to the home set-constructor who wishes an efficient, sensitive and compact receiver. In it are combined the advantages of a.c.-d.c. filament operation, high sensitivity and relative freedom from noise due to

*Eilen Radio Labs.

- C1, C2, C5—.01 mf., 200-volt solar cortridge condenser.
- C3, 0.00014 mf. Hommarlund variable condenser
- C4, C8—0.5 mf., 200-volt solar cortridge condenser.
- C6, C7—0.0001 mf. Aerovox mica condenser.
- C9—.1-.1 mf., solar 200-volt cartridge condenser.
- R1—300-ohm, 1/2-watt resistor.
- R2—60,000 ohm., 1/2-watt resistor.
- R3—100,000 ohm, 2-watt Clarostat variable resistor.
- R4—3,000,000-ohm, 1/2-watt grid resistor.
- R5—1,800-ohm, 1/2-watt bias resistor.
- R6—325-ohm, 25-watt filament resistor.
- T—Audio transformer, 3-1 ratio.
- L1—2 mh. Eilen s.w. r.f. choke.
- L2, L3—Eilen plug-in coils, wound on 1/4-in. forms.
- L4—2 mh. Eilen s.w. r.f. chokes.
- Eby ont. ond gnd. twin binding post strip.
- Eby phone binding post strip.
- 1—Eby 4-prong wafer socket for small base tubes.
- 1—Eby 5-prong wafer socket for small base tubes.
- 1—Eby 7-prong wafer socket for small base tubes.
- 1—6F7 tube.
- 1—37 tube.

SUMMARY: Although the triode-pentode tubes were originally designed for superheterodynes, their use in other types of receivers is becoming universal. For instance, the "DX-2" uses the 6F7 tube in a unique circuit, in which one tube takes the place of two; thus, this two-tube set gives the same results as sets using three ordinary tubes.

By Luther J. Miles*

the use of B battery plate supply. The application of the 6F7 tube to this receiver results in three-tube performance with the cost and upkeep of only two tubes.

The Electrical Circuit

The circuit diagram, illustrated in Fig. 1, is seen to consist of an untuned radio-frequency amplifier using the radio-frequency pentode section of the 6F7 tube, a regenerative detector utilizing the triode portion of the same tube, and one stage of audio-frequency amplification employing the type 37 tube.

The use of the untuned radio-frequency stage prevents radiation from the receiver, renders the receiver less susceptible to variations in the antenna system, eliminates dead spots and the necessity of an antenna series condenser, and provides considerable gain, which is of immense value in the reception of very weak and distant stations.

The antenna is coupled to the radio-frequency amplifier by means of the radio-frequency choke coil, L1. A choke having an inductance of approximately 2 mh., and having an extremely low distributed capacity, should be used in this position.

If desired, one may substitute a resistor of approximately 50,000 ohms for the r.f. choke.

Bias for the radio-frequency stage is obtained by means of the cathode resistor R1, which must be bypassed by the capacity C1. The screen-grid voltage is reduced to the proper value by means of the series resistor R2. The use of capacity C2 is necessary in order to maintain the screen grid at ground potential as far as radio-frequency potentials are concerned.

Tuning is accomplished by means of the midget variable condenser C3 (0.00014 mf.), which shunts the plate coil L2. A smaller coil, L3, is wound on the same form as L2 and furnishes the necessary feedback. Four plug-in coils are employed, enabling the receiver to cover the short-wave range from 16 to 200 meters. By the use of an additional pair of coils, the user may also cover the entire broadcast band. Regeneration is controlled by means of the 100,000-ohm variable resistor R3, having a rating of 2 watts. A capacity of 0.5 mf., C4, bypasses this control in order to reduce noise resulting from its movement. Grid leak and grid condenser detection is

(Continued on page 40)

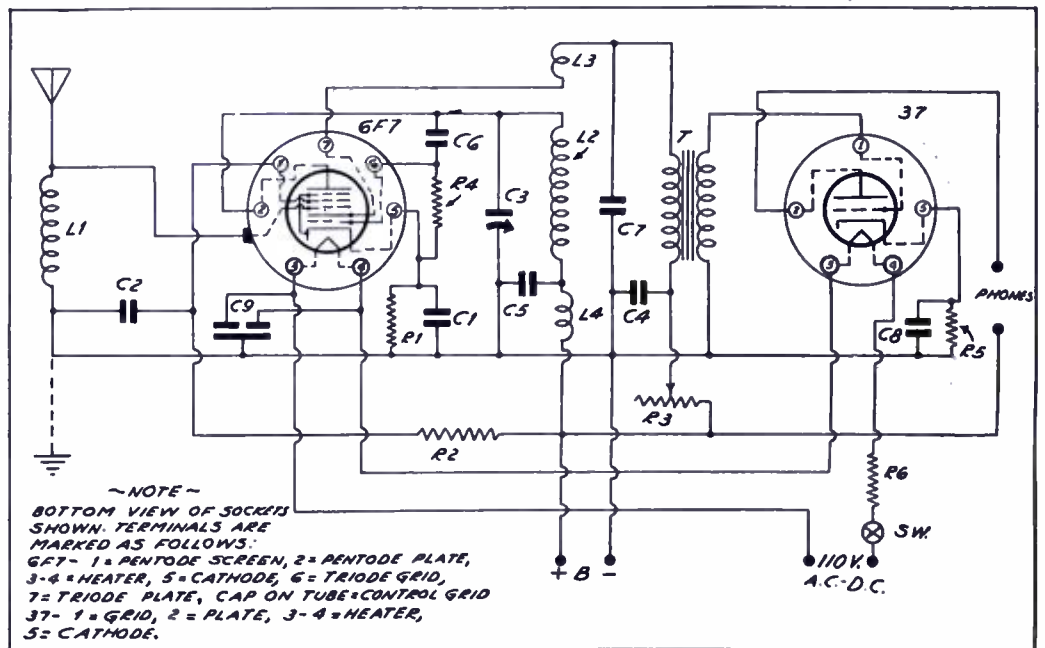

Fig. 1:—Schematic circuit and list of parts for the "DX-2."

- SW.—Rotary switch, 250-volt, 3 ampere rating.
- 1—Kurz-Kasch vernier dial, 4 in. type.
- 2—Kurz-Kasch bakelite knobs.
- 1—roll hook-up wire

- 1—special metal chassis and panel, finished in black crystalline lacquer (Eilen).
- 1—tube shield.
- 1—screen-grid clip.
- 1—pair phones.
- 3—B batteries, 45-volt type.

A Two-Tuned-Stage Short-Wave Booster

SUMMARY: A description of a booster, or pre-selector, that uses two tuned r.f. stages and that is designed for operation with most short-wave receivers. This booster will increase selectivity, reduce image interference and tube noises, and increase volume. It is especially designed for those receivers which have no preselection and which need the advantages to be gained by the use of additional r.f. amplification.



Panel view of the preselector described.

OWNERS of regenerative, t.r.f.-regenerative and the simpler forms of super-heterodyne short-wave receivers have long felt the need for a higher degree of selectivity, and, to a slightly lesser extent, for higher sensitivity. In the case of super-heterodynes, the lack of pre-selection ahead of the first detector is responsible for image-frequency interference, which can sometimes be extremely annoying. The National Company recently put out a special pre-selector-amplifier for its popular FB7 receiver, and now Postal Radio brings forth a completely self-contained and self-powered "Booster Unit" that will work with most standard short-wave sets.

Electrically, the unit comprises two complete stages of tuned radio-frequency amplification using type 78 tubes. The two r.f. transformers L1 and L2 are built into a partitioned shield can that slides like a drawer into a square opening in the front panel. Connection to the coils is made by wiping spring contacts that press against raised buttons on the top of the "drawer." Four pairs of coils, tuned by the double condenser C1 (140 mmf. per section) give the booster the usual wavelength range of 14 to 200 meters.

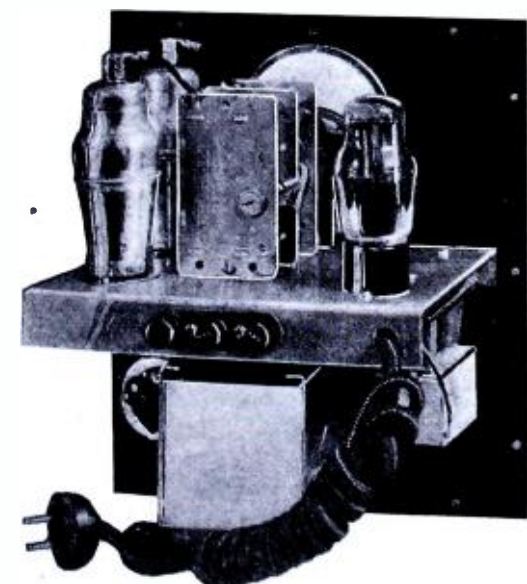

Rear view, showing the arrangement of the tubes, including the 25Z5 rectifier.

Volume is controlled by the 12,000-ohm variable resistor R1, which merely regulates the control-grid bias of the two 78's. The primary of the antenna r.f. transformer L1 is brought out to two separate binding posts, so as to permit the connection of a transposed-wire feeder. When a regular antenna is used, one of these posts is simply grounded to a third and adjacent post.

A single-pole, double-throw snap switch, SW2, mounted on the front panel, throws the aerial to the receiver direct or to the booster. It is a simple matter, of course, to use a double-pole switch in this position for switching a two-wire feeder.

The output of the booster is fed through condenser C4 into the input of the receiver as shown, a shielded lead being provided for the plate-to-aerial post connection.

The filaments of the 78's and the 25Z5 rectifier tube are wired in series with an additional 290-ohm

voltage dropping resistor. Plate voltage is furnished by the 25Z5, which has its two plates connected together to make the tube act as a half-wave rectifier. A filter system consisting of the 30-henry choke, L4, and the dual electrolytic condenser, C6-C7, irons out the ripples of the rectified current.

The nature of the power-supply circuit permits the booster to be used on either alternating or direct current without change. For d.c. service, it is merely necessary to "pole" the line attachment plug properly.

The booster is housed in a strong metal cabinet finished in spot-proof black crystal. It measures 10 inches high, 8½ inches wide, and 6 inches deep, and looks very attractive.

The editors of SHORT WAVE RADIO tested this new booster with three different superheterodynes and one t.r.f.-regenerative receiver, and can report that it works very well. Two of the supers already had
(Continued on page 30)

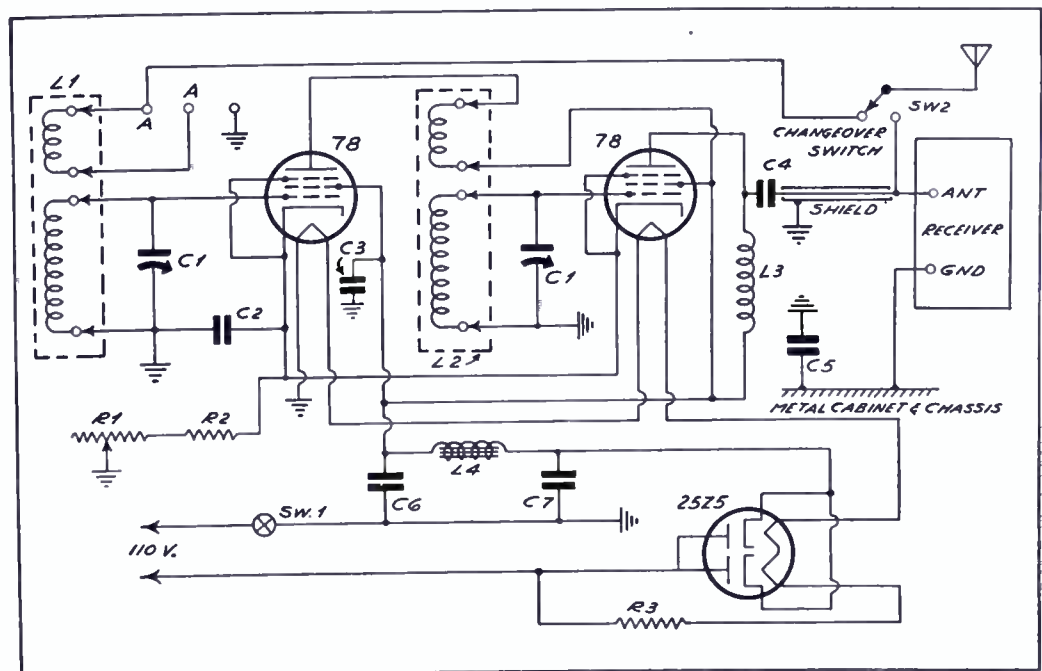

Schematic circuit and list of parts for the booster.

- L1, L2—R.F. transformers in single "drawer."
- L3—8 mh. r.f. choke.
- L4—30-henry filter choke.
- C1-C1—Dual variable condenser, 140 mmf. per section.
- C2, C3—.1 mf. bypass condensers.
- C4—.001 mf. coupling condenser.

- C5—.5 mf. condenser.
- C6, C7—8 mf. electrolytic filter condensers.
- R1—12,000-ohm resistor.
- R2—300-ohm resistor.
- R3—290-ohm line resistor.
- SW1—Line switch, combined with R1.
- SW2—Changeover switch.

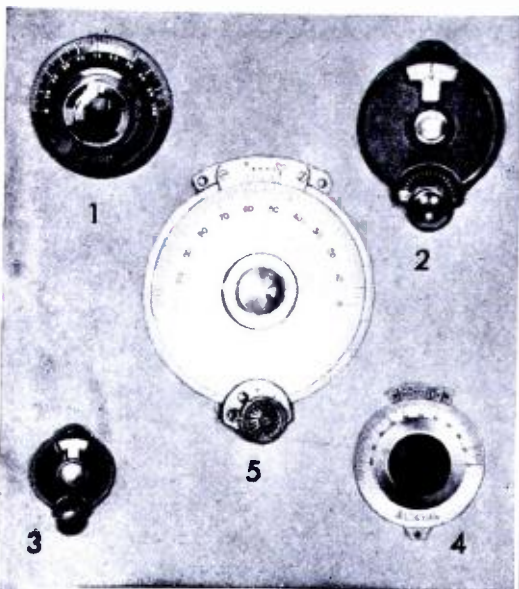

for PRECISE CONTROL

For tuning and exact logging of short wave receivers, for precise control of transmitters, monitors, frequency meters and experimental apparatus—in short, for every application in short wave radio where consistently accurate, smooth operation is required—there is a NATIONAL Velvet-Vernier Dial.

1. The original Velvet-Vernier Dial, Type A; more widely used by amateurs than any other dial ever made. Its smooth and matchless mechanism gives a drive that is always even and positive, permanently free from back-lash. Ratio is 5 to 1.
2. The Type B Dial. With black bakelite shell 4 in. diameter. The ratio is variable from 6-1 to 20-1. Available with or without dial-illuminator.
3. Type BM Dial; a 3 in. midget model similar to the Type B but without the variable ratio feature. For small receivers and other equipment where space is limited.
4. The Type N Dial. Solid engine-divided German silver 4 in. Dial with the unexcelled Type A Mechanism. Fitted with precision vernier reading to 1/10 division.
5. Type NW 6 in. Instrument Dial. Made with extreme precision and equipped with flush vernier permitting accurate estimation of reading to 1/20 division. Engine-divided scale on solid German silver. Type B mechanism has 3 point variable ratio.

The complete line of NATIONAL Velvet-Vernier Dials, together with NATIONAL Short Wave Receivers, Power Supplies, Variable Condensers, Transformers and Accessories, are fully described and priced in our new Catalogue No. 220. Use the coupon below.

NATIONAL VELVET VERNIER DIALS

COUPON



National Company, Inc.
Malden, Massachusetts

Gentlemen:
Please send me your new catalogue No 220. I enclose 6c to cover mailing costs.

Name

Address

SWR-6-34



Revamping the Super-Wasp

(Continued from page 27)

the particular loudspeaker that is to be used with the set. A small dynamic speaker is desirable, but the old Pilot K-111 power pack furnished with Super-Wasp does not have sufficient output capacity for the field.

A permanent magnet dynamic speaker is ideal, as it involves no bother with field current. The third possibility is a magnetic speaker. When the set owner selects a speaker, he must be careful to include an output transformer that will couple a 2A5 to the voice coil or driving unit. As transformers of widely different characteristics look alike, it is a good idea to insist on a guarantee of performance. Dynamic speakers usually have their coupling transformers mounted right on their own frameworks. Transformers for magnetic speakers invariably must be purchased separately.

As the revamped circuit shown in Fig. 2 is practically foolproof, no trouble will be encountered. Of course, a reversed tickler may prevent the set from oscillating, but after this has been switched the set will "perk" immediately.

Lest some people get the idea that revamping of an "old" set of this kind is not worthwhile, it might be remarked that the Super-Wasp is still being sold, and many people today are first starting to try it in its original form.

The 6C6 and 6D6

(Continued from page 23)

biased detector were obtained by adjusting grid and screen voltage for each of the three loads and observing the optimum voltage output consistent with good wave-form. The cathode-ray oscillograph was used for observing the waveform.

In the above tests the output voltage was held constant at 17 volts peak with modulation of 20 per cent. When modulation was increased to 60 per cent, some flattening of the lower peaks was observed for the conditions of II and III. With 70 per cent modulation, this effect was very pronounced for III and was just starting for I. Hence, best operation for the 6C6 as a detector is obtained with the conditions shown in I.

Mixer Operation of the 6D6

The 6D6 may be employed as a mixer in superheterodyne circuits having 100-volt supply. For this use, the following conditions apply.

Heater voltage	6.3	volts
Plate Voltage	100	volts
Screen Voltage	100	volts

Suppressor Connected to Cathode at Socket

Grid Voltage -10* approx. volts

*This value is minimum for an oscillator peak voltage of 7 volts.

—RCA-Radiotron Co., Inc.

Coffee Can Meter

(Continued from page 35)

to the regular antenna post on the receiver by merely twisting it around the post—do not connect it. Also, be sure that the aerial wire is disconnected. It might also be feasible to wrap the antenna lead of the oscillator around a short piece of wire which is connected to the antenna post of the set.

The last point (going up in wavelength) at which the oscillator can be heard is the fundamental frequency of the oscillator. Then turn the oscillator dial to 90 and repeat the procedure, bearing in mind that the highest wavelength on which the oscillator can be heard is the fundamental frequency of the oscillator and is the one to be jotted down. Continue this operation for every ten degrees on the ordinary dial.

Now, plot a curve for the oscillator, just as you did for the receiver. Such a curve is Curve 1 in Fig. 3. Since the oscillator produces harmonics, every degree on the oscillator dial corresponds to many different frequencies, each being a multiple of the fundamental. Harmonic curves may then be drawn by multiplying the fundamental frequency of each 10 degrees of dial setting of the oscillator by 2, 3, 4, etc. These curves are labeled in the margin. The fundamental range of coil No. 1 is from about 1750 to 3400 kc.

Exactly the same procedure is followed for the second coil. The range of the second coil is from about 3000 kc. to 6000 kc. Thus, coil No. 1 may be used for the location of all stations between 1800 and 3500 kc. and coil No. 2 for the location of stations from 3500 kc. up.

This little oscillator can do wonders in the hands of an experienced manipulator. Once calibrated, it may be set for any particular station frequency, and the receiver adjusted to it. Only a slight readjustment of the receiver dial is then necessary to pick up the station, if the set can pick it up. Furthermore, any receiver can be calibrated in a few moments by merely reversing the process described previously.

EXPLORE THE HITHERTO UNEXPLORED LONG WAVES USING YOUR OWN SHORT WAVE SET!

The new H. B. long wave plug-in coil and its two fixed capacitors will enable you to reach from 450 meters to 1640 or 1740 or even up to 2140 meters, according to the size tuning condenser you use in your set. Listen to the ships on 600 or 715 meters and Radio Compass stations on 800 meters. Airliners on 900 and Beacons on 1,000 meters.

4 prong H. B. Long Wave Coil and 2 capacitors **\$2.50**

Please mention make of coil and size of condenser used in your set.

16 Gauge Aluminum Panels

7 x 10...24c 7 x 12...28c 7 x 14...32c
These panels are a special lot at the above prices. Longer and wider at correspondingly low prices. Add postage on 1 lb. for each.

We have no catalog. Please do not ask for one.

BLAN THE RADIO MAN, INC.

177 Greenwich St. Dept. HM New York, N. Y.

Program Notes

(Continued from page 6)

who object to the change — — — but we believe that the new system will be found to work for the general convenience of listeners. In any undertaking the work of which extends regularly beyond midnight the necessity of explaining whether a given hour is A. M. or P. M. is apt to lead to confusion. The Empire broadcasting programmes, for instance, cover a considerable part of the twenty-four hours each day, and alone form a justification for the change. A further source of confusion in the use of A. M. and P. M., so far as this journal is concerned, occurs with some frequency in the case of a reader desiring to know the identity of a foreign station a programme item of which was heard at (say) '12.10.' In the absence of the indicative letters it may be impossible to give a certain answer, whereas if the time had been expressed as '00.10' all doubt would have been removed."

Time is Not Standardized

The failure of different nations to agree on a standard method of indicating time has led to many international difficulties. Different branches of the same government are not even always in agreement. For instance, the United States Army uses the double 12-hour clock, where as the Navy uses the 24-hour system.

In this connection, readers are urged to buy a simple time conversion chart, or make the one described on page 17 of the April, 1934, issue of SHORT WAVE RADIO.

S.W. Booster Unit

(Continued from page 37)

pre-selector stages, so with them the additional sensitivity was noticeable. The other super had no pre-selection and suffered badly from image-frequency interference; the booster eliminated this trouble completely. The t.r.f.-regenerative set was improved 100 per cent, both the selectivity and sensitivity being better than before. Stations in the crowded 25- and 49-meter broadcast channels could be separated quite comfortably, whereas previously they were all jammed together in a homeless mass.

With the superheterodynes, the additional signal-frequency amplification provided by the booster allowed the sets themselves to be worked at a lower level than previously, with the result that the noise level decreased noticeably. The beneficial effects of pre-selection and amplification ahead of the first detector of supers are now well known.

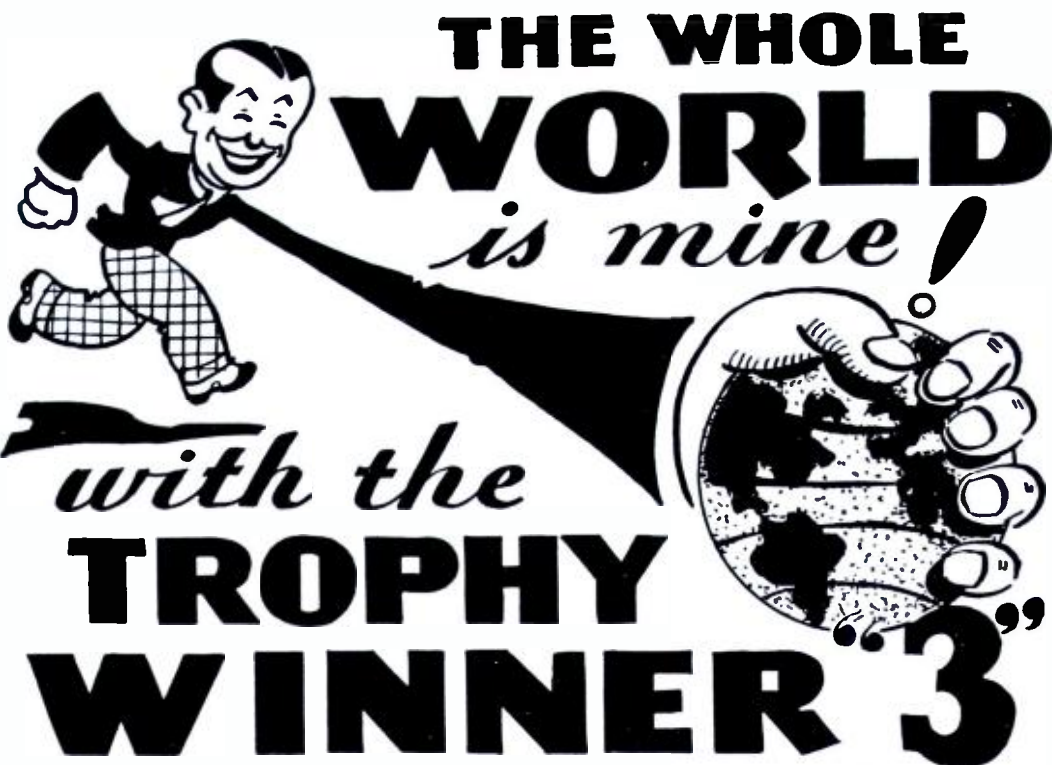

That's just what you'll say when you put this newly designed, simplified, 3-tube short-wave receiver kit into operation. And what pleasure you'll derive from building it! It's as easy to assemble as a 1-tube set!

EXTREME SIMPLICITY AN OUTSTANDING FEATURE

All parts in the Trophy Winner "3" are so placed that an absolute minimum of wiring and soldering is required. This design, which was worked out in our own laboratories and is exclusive with us, cuts down the chances for error in wiring, thus assuring the kind of reception usually found only in the most expensive sets. The separate power supply, which operates from A.C. house current, is free from hum.

SPECIAL POWER PACK KIT

The Trophy Winner "3" employs a special 3-winding coil to couple the R.F. and detector. When wired the receiver connects directly to the voice coil of the dynamic speaker or to head phones.

The power supply kit contains heavy chassis, power transformer; employs 3 mfd. filter condensers; two 30-henry filter chokes . . . all over-sized. Output: 250 v. at 50 Ma.

The Trophy Winner "3", when assembled, "steps out" and brings in the most elusive distant stations. Truly the whole world is yours to roam with this 3-tube sensation!

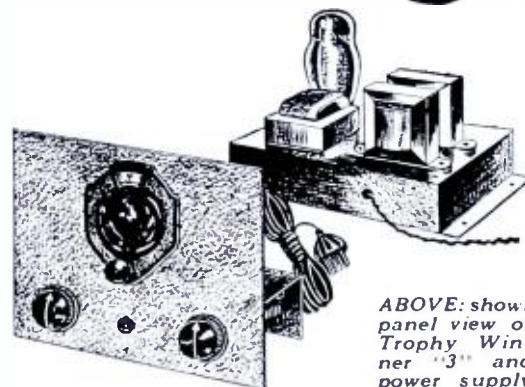

ABOVE: shows panel view of Trophy Winner "3" and power supply



LEFT: Photo showing back view of the set. Note its simplicity of design

- SN13905 Trophy Winner "3" A.C. kit of parts complete with wiring diagram, less coils, tubes, power supply . . . **\$9.95**
 - SN 13906 Power supply kit of parts, less tubes **\$4.95**
 - SN 13907 Special Coils, 16-200 meters . . . **\$2.25**
 - SN 13908 Kit of matched tubes for receiver and power supply **\$2.30**
 - SN 13985 Complete kit of parts, set, power supply, coils and tubes **\$18.45**
- Also Available Wired, Ready to Use, at Slightly More

BIG Free CATALOG FROM Short Wave Headquarters!

America's greatest Radio Values. Over 10,000 listings in this 80 page supplement to catalog 55. Last minute price reductions. Big Special Department on S.W. Every conceivable Short-Wave Accessory listed. . . . all at lowest wholesale prices! Don't fail to get your copy today!



WHOLESALE RADIO SERVICE CO.
100 Sixth Avenue, Dept. SWR-64
New York, N. Y.

- Send me your FREE catalog 55 C.
- Send me items I have listed in the attached letter. I enclose \$ to cover cost
- Send me descriptive folder on the Trophy Winner "3"

Name
Address
City State

WHOLESALE RADIO SERVICE CO. INC.
100 Sixth Avenue, New York, N.Y.
New Branch
219 Central Avenue, Newark, N.J.

Leeds Introduces

a New Service and a number of new units designed for the amateur. Wait until you see our new 5 meter apparatus, new low frequency transmitters, LEEDS "demi-bases," but enough just look over the gadgets described below.

LEEDS Type 1-B Frequency Meter Monitor

This instrument sets a new standard in frequency meter design. This 2 purpose instrument furnished complete with 2 tubes and large calibration chart for **\$19.75**
Complete kit (4 parts (less tubes) **\$11.45**

Type 1-A Frequency Meter, for general short wave coverage, is also available. This instrument is similar in appearance to the 1-B but the electron coupled oscillator operates in the broadcast band so that its harmonics cover the entire short wave spectrum. A modulated oscillator takes the place of the detector employed in the amateur model, so that an easily recognizable signal may be heard in short wave receivers that do not have a beat oscillator incorporated in them. Furnished complete with 2 tubes and calibration chart **\$19.75**

LEEDS Type 1-C Wave Meter

For the first time an absorption type wave meter with real bandwidth. Each amateur band from 5 to 160 meters covers 50 degrees or more on the dial (16 coils). General coverage from 12 to 200 meters also available (14 coils). A 3 1/2" cube that can be put into a tight corner without difficulty. Furnished with a 60 mil indicating lamp, so that its sensitivity compares favorably with a thermogalvanometer. Completely wired, tested and calibrated with 10 coils **\$15**

Complete kit of parts with instructions and 6 unbound coil forms **\$4.25**

LEEDS Type 1-D Frequency Meter Checker

Employing a type 24 tube in a 10 kc. E.C. oscillator circuit. In conjunction with a T. R. F. broadcast receiver, accurate 10 kc. checking points may be obtained throughout the 80 and 160 meter bands for frequency calibration at any time. An inexpensive substitute for 100 kc. bars, multivibrators, etc. Fully furnished wired and tested with tube for **\$9.25**

Complete kit of parts with instructions and 6 unbound coil forms **\$5.31**

LEEDS Type 1-E Power Supply

Housed in attractive black crystalline finished steel can 5x6x9—employs type 280 rectifier, double section filter with 18 mfd. condenser to insure humless operation. B supply 225 v., 35 mls. A supply 212 v., 5 amp. Output multiplied to two UX sockets to fit the 1-A—1-B or 1-D, UX plugs. May also be used with the SW-3 AC receiver. **\$8.35**
Price (less tubes)

The Radio Amateur has found it convenient to shop at LEEDS. Only quality merchandise at wholesale prices.

We do not publish a catalog; quotations on all short wave equipment furnished by return mail.



45-G Vesey Street, New York City
New York Headquarters for Short Wave and Experimental Apparatus

The "DX-2"

(Continued from page 36)

used. Values of 3,000,000 ohms and 0.0001 mf. respectively are quite satisfactory. Higher values of grid leak resistance result in a somewhat greater sensitivity to extremely weak signals, whereas lower values produce slightly better tone quality and stability.

The bypass capacity C5 serves the double purpose of preventing a short-circuiting of the r.f. amplifier plate voltage to ground and tends to prevent the entrance of radio-frequency currents into the plate supply voltage source. The latter function is aided by the second radio-frequency choke coil, L4. Because of its large capacity (0.1 mf.), C5 has negligible effect upon tuning. It should be noted that the grid-leak return connects to the cathode terminal of the tube socket, and *not* to ground. This prevents the r.f. amplifier grid bias from being placed upon the detector section of the 6F7. Capacity C7 serves as an aid to regeneration and also bypasses radio-frequency currents around the audio amplifier. A value of approximately .0001 mf. is sufficient.

Since the plate resistance of the 6F7 triode section is relatively small, transformer coupling to the audio-frequency amplifier is used. A transformer having excellent frequency characteristics should be used for best results. Bias for the amplifier is obtained by means of the cathode resistor R5, whose value is 1800 ohms. A bypass capacity, C8, of 0.5 mf. is shunted around this resistor in order to minimize distortion.

The tube filaments of this receiver are lighted directly from the 110-volt a.c. or d.c. house-lighting circuit, the current being limited to the proper value by means of the series resistor R6. This resistor should have a value of 325 ohms and should be capable of dissipating 25 or 30 watts continuously. An alternative arrangement permitting a.c. filament operation would be to connect the tube filaments in parallel and operate them from a small step-down transformer. Either of the above arrangements results in the elimination of an unsightly storage battery or expensive dry-cell replacements. Provided certain precautions, to be mentioned later, are observed, the receiver should be quite free from any objectionable a.c. hum.

In order to obtain the maximum freedom from noise, so essential to reception of very weak stations, the use of B batteries for the plate voltage source is recommended; 135 volts of B battery will give excellent results with this receiver. However, a well-filtered power supply of the proper voltage may be used if desired.

Construction

The complete receiver is assembled upon a metal chassis of dimensions

8 x 7 x 2 1/4 inches, and a panel measuring 8 x 7 inches. Both the chassis and panel are finished in durable black crystalline lacquer, presenting a very pleasing appearance.

In wiring the receiver, care should be taken to make all leads as short as possible. One terminal of the resistors R1, R2, R4, R5 and condensers C1, C2 and C8 should be soldered directly to the tube socket terminals. All tube socket connections may be readily made by referring to the corresponding numbers on the sockets of Fig. 1. The leads carrying filament current should be carefully twisted throughout their length in order that the a.c. fields surrounding these wires may be neutralized as much as possible. In extreme cases it may be beneficial to employ shielded wire for the filament circuits. All leads, particularly those associated with the grid and plate circuits of the radio-frequency amplifier and detector, should be kept as far as possible from the filament wiring. A connection should be made from the rotor plates of the tuning condenser to the coil L2. Do not depend upon the condenser-frame-to-panel contact for this connection. The use of a ground connection with this receiver is not essential, since an excellent radio-frequency ground is obtained automatically through the a.c. house lighting circuit supplying the filament current. The dual section condenser C9 (.1 mf. per section) is used to bypass the a.c. filament circuit to ground in order to minimize hum. The use of a tube

(Concluded on next page)

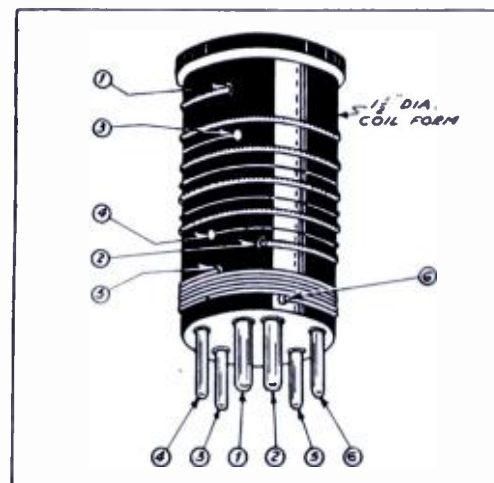

The numbered ends of the various windings connect to the correspondingly numbered base pins.

COIL WINDING DATA

Wave Band	Secondary No. Turns*	Tickler No. Turns†
10—20	4-3/4	6-3/4
20—40	9-3/4	9-3/4
40—80	19-3/4	14-3/4
80—200	53-3/4	25-3/4

*No. 20 single silk cotton covered, close wound.

†No. 20 enameled wire, close wound.

Short Wave Reception

AT ITS BEST—
WITH THE NEW

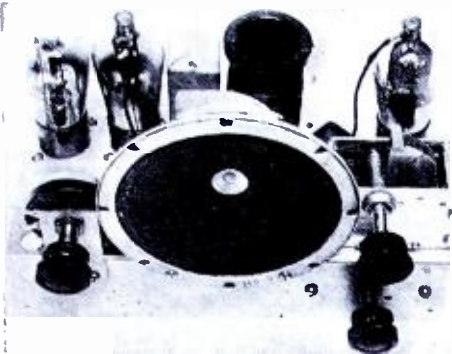

INTERNATIONAL THREE

WORLD WIDE RECEIVER

A.C.-D.C. Self-powered Kit, with built-in speaker, coils to cover 15 to 200 meters, and blue print..... **\$6.75**
 Custom built and laboratory tested for World Wide Reception..... **\$7.95**
 Broadcast Coil 200-500 meters..... **\$1.75**
 Kit of matched Arcturus Tubes..... **\$2.25**

EXPERIMENTAL RADIO LABS.,
 80A Cortlandt St. New York City, N. Y.



McMurdo Silver MASTERPIECE II 10-570 METERS



proclaimed greatest all-wave receiver by engineering universities, broadcast executives and explorers.

Admiral Byrd is using Masterpiece II in the Antarctic . . . the Engineer of a Great Eastern University writes, "Masterpiece II is my ideal come true" . . . Broadcast Executives prefer Masterpiece II for their own use, because of its lower noise level and consequent better reception of far distant stations. Many unique features such as band spread tuning, built in beat note oscillator. Write for complete details and particulars of 10-day trial, money-back guarantee offer.

McMURDO SILVER, INC.
 Dept. 1751
 1751 Belmont Ave., Chicago, U.S.A.

shield for the 6F7 is also recommended.

If filament battery operation be preferred, the tube filaments may be connected in parallel and operated directly from a six-volt storage battery. In this case the use of resistor R6 and capacity C9 is unnecessary.

This receiver has given excellent results when used with a reasonably good antenna system. Foreign stations have been consistently received, many of them at loudspeaker strength when conditions are favorable. Short-wave broadcasting, police stations and thousands of telegraph stations may be received with equal ease.

New Aircraft Rules

(Continued from page 15)

raphy only. Study has been given to the desirability of permitting the use of radiotelephony, but it is believed that this method of handling public correspondence should not be permitted at this time. In this connection, attention is invited to the fact that only radiotelegraphy is used by other licensees in the United States when handling public message correspondence which is filed by the sender in written form. A station open to public correspondence must accept messages in code groups, cipher or foreign language; if radiotelephony is used the aircraft and ground station operators would have difficulty in transmitting, receiving and transcribing such messages.

3. The regular aviation emergency frequencies will not be used for the handling of public correspondence. The Commission has allocated three frequencies, namely, 4335, 4480 and 4495 kilocycles, for assignment to aircraft and aeronautical stations desiring licenses for public service. The ideal frequencies for this service lie in the bands 2850-3500 kc. and 5000-5700 kc. However, frequencies in these bands are not available because of their prior assignment.

4. Licensees will not be permitted to transmit public service messages by radio from point-to-point between ground stations. Wire facilities are available for this purpose.

5. The person actually at the controls of an aircraft in flight shall not perform any duties incident to the handling of public correspondence. He shall be the sole judge as to whether or not the conditions existing at the time of filing a public service message will permit the handling thereof by any other person aboard the aircraft. Furthermore, arrangements shall be made so as to prevent access to the pilot's compartment by the public in connection with the handling and filing of public correspondence.

6. Applicants desiring licenses to operate stations in the aviation public service must show that they are legally empowered to handle public message correspondence and that they assume the usual obligations of a public utility corporation.

STUDY AT HOME!

COME to WASHINGTON!

PRACTICAL RADIO ENGINEERING

—in 3 convenient courses

for men who want to
get ahead in Radio!

This is the most thorough Radio Engineering course offered by any school in the U. S. . . . available in home-study and residence courses and a combination of them both. Let us explain how they can be adapted to your personal need.

Write for Our New
Complimentary
40-Page Booklet

With pictures and full
details of our courses
and laboratories.

CAPITOL RADIO

ENGINEERING INSTITUTE

14th and Park Road, N. W.
 Dept. SW-6, Washington, D. C.

ALLIED And The AMATEUR

The new ALLIED catalog, which is yours FREE for the asking, lists the most complete line of transmitting and receiving materials you could ask for . . . priced right, and available quickly. Every AMATEUR needs the valuable new ALLIED book. Send for it today. It is packed with AMATEUR equipment representing the famous quality products of:

R. C. A.-DE FOREST
 THORDARSON
 CARDWELL
 JOHNSON
 BLILEY
 R. E. L.
 SPRAGUE
 NATIONAL
 HAMMARLUND

And Many
Other Quality
Standard Lines

SEND FOR THE NEW
FREE ALLIED CATALOG

ALLIED RADIO CORPORATION

833 W. JACKSON BLVD., DEPT. L
 CHICAGO, ILL.

Please send me your FREE NEW 1934 Radio Catalog with the complete Amateur Listing.

Name.....

Address.....

City..... State.....

Allied

NEW 4 TUBE ALL-WAVE RADIO



FREE TRIAL!

Special Offer for limited time. This new 4-tube ALL-WAVE AC-DC all purpose set complete with tubes only \$17.00. Ideal for radio amateurs; has remarkable band spread; fine reproduction; gets results on CW. Tunes 15-2700 meters (110-20,000 kc.). Operates anywhere, with adapter on cars, boats, farms; 6.32, 220 volts. Efficient built-in aerial (exceptional performance on our new All-Wave aerial); Dynamic speaker; latest type RCA-Cunningham tubes; RCA licensed. A sensational bargain! Carries our money-back guarantee: 30-day FREE TRIAL in your home. To buy at this price you must ORDER NOW.

All regular broadcasts coast to coast, police calls over wide area amateur and trans-Atlantic phone, code, commercials; foreign stations; ships; airplanes—with remarkable band spread!

\$17.00
COMPLETE

COMPLETE LINE—AMAZING PRICES!

Fordson guaranteed radios for every need: AC-DC; Dual and All-Wave; consoles; special 6-tube car radio value! From 4-tube 2000-mile range midgets that get police to 8-tube All-Wave world-wide sets. Modernistic cabinets.

BIG CATALOG FREE!

See all of these unusual values in our new, big FREE catalog, just off press. Get our agent offer that spells money, big money! Free samples. Prices will amaze you from \$9¹⁵ up. Send the coupon back TODAY!



FORDSON RADIO, Inc.

Dept. 6-41 Oakman Bldg.,
Detroit, Mich.

Send me FREE catalog and agent offer (this is NOT an order).

Name

Address

HOW TO LEARN CODE

Thousands of operators agree no "system" of printed sheets can teach you the Code. TELEPLEX has taught Code to more operators in past 10 years than all other methods combined. YOU can learn Code—or step up your w. p. m. amazingly—this surer way. No experience needed. Beginners, amateurs, experienced ops get ahead faster with Teleplex. It doesn't merely "show" you Code—it IS Code! You actually HEAR dots-dashes any speed you want. Sends you practice messages and SENDS BACK your own key work, which no other system can do.

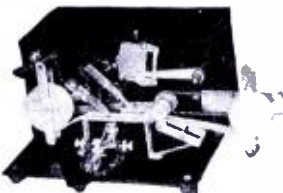

For quicker license find out about this better way used by U. S. Army, Navy, R. C. A., A. T. & T., and many others. We give you complete course, lend all equipment, give personal service on MONEY-BACK GUARANTEE. Low cost, easy terms. Without obligation write for booklet S. R. 18.

TELEPLEX COMPANY

76 Cortlandt Street

New York, N. Y.



FREE 1934 WHOLESALE RADIO CATALOG

Radio Replacement Parts, Sets, Tubes and Electrical Appliances at great savings.
WHOLESALE MERCHANDISERS, Inc.
628 Broadway, - New York City

Tuning the Antenna

(Continued from page 16)

As previously mentioned, C1 may have a value of between 25 and 100 mmf. maximum, depending upon the size of the individual antenna, the length of the ground lead, and the type of primary employed in the receiver. It is suggested that a switching arrangement be incorporated which permits either series or multiple tuning at will. Such a circuit is shown at D of the figure.

In circuits B and C dead spots may occur exactly as in circuit A. However, they may be eliminated to a large extent in two ways: either by increasing the distance, or magnetic coupling, between the primary and the secondary; or, what eventually amounts to the same thing, by reducing the number of turns on the primary and increasing the size of the antenna condenser to bring the circuit into resonance. The loose coupling has the effect of reducing the load on the tuned circuit so that the set can oscillate easily.

Tuning antenna systems to resonance with a desired signal is, in many cases, equivalent to adding another good stage of r.f. to the set. It increases the apparent selectivity of the receiver and also effects a reduction in the noise level. Every constructor of a short-wave receiver should try antenna tuning at the first opportunity.—L. M.

Some Super Notes

"Mushy" reception may not be due to any inherent fault of the signal arriving at the antenna, but to poor design of the receiver, especially in supers. Careful tracking of the condensers and close alignment of the i.f. transformers may eliminate this difficulty in many cases.

A good idea in supers—especially if they are homemade—is to make one of the trimmer condensers on the oscillator tuning unit variable, with its knob extending through to the front panel. A slight readjustment, after tuning in a signal, may clear up a lot of this "mush." Additional information on this will appear in an early issue.

"Who Is C.Q.?"

Newcomers to the short-wave game who listen in on the amateur 75- and 160-meter phone channels are much mystified by the station "CQ" that every amateur in the world seems to be calling at any given hour of the day or night.

"CQ" is not a station. It is the international signal of inquiry and means simply that that calling station is on the air and wants to communicate with any other station that happens to hear it. In other words, it is an invitation to get together.

Twice as Big as Before!

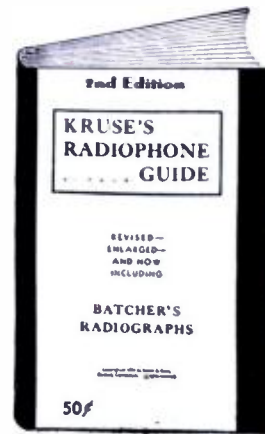

is
the new
2nd
edition
of

KRUSE'S RADIOPHONE GUIDE

and just as full of operating and constructional information which isn't printed elsewhere.

And furthermore—

There's a complete set of
Batchers "Radiographs"
the simplest problem-solvers we ever saw.

IN STOCK AT—

Thompson Holmes, San Francisco
Walter Ashe Radio Co., St. Louis
G. M. & C. Radio Sup. Co., Oakland
Zack Radio Sup. Co., San Francisco
Radio Specialties Co., Detroit
Warner Bros., San Francisco
E. C. Wenger Co., Oakland
Leeds, New York
Ottensbach Elect. Co., San Francisco
I. S. Cohen's Sons, San Francisco
Neisner Bros., Inc., Boston
J. C. Hobrecht Co., Sacramento
Portland Radio Sup. Co., Portland
Griffith Sales Co., Tacoma, Wash.
Wedel Co., Inc., Portland
Wedel Co., Inc., Seattle
Seattle Radio Sup. Inc., Seattle
Lou Bonn Co., St. Paul
Chicago Radio Apparatus Co., Chicago
Spokane Radio Co., Inc., Spokane
Midwest Radio Mart, Chicago
Gross Radio, Inc., New York
Intercity Radio Stores, Long Beach
American Sales Co., New York
Burstein-Applebee Co., Kansas City
Aubott's Sweet Shop, Berwyn, Ill.
T. F. Cushing, Springfield, Mass.
Ports Mfg. Co., Fresno
Radio Inspection Service, Hartford
Radio Supply Co., Los Angeles
Hafry & Young, Hartford
Kronson Service Co., Buffalo
Pierson's Radio Laboratory, Sacramento
Blair the Radio Man, New York
Wilmington (Delaware) Elec. Specialties Co.
Kladag Radio Laboratories, Kent, Ohio
Maurice Schwartz & Son, Schenectady
Harry's Radio Land, Long Beach
Radio Service Laboratory, Manchester, N. H.
Thompson Battery and Radio Service,
Zanesville
Radio Laboratories, Kansas City
Radio Electric Service Co., Philadelphia
Chicago Radio Apparatus Co., Chicago
Cameradio, Pittsburgh
Natick Book Store, Los Angeles
Radio Distributing Co., South Bend, Ind.
Radio Television Sup. Co., Los Angeles, Cal.
Neisner Bros., Rochester, N. Y.
Electric Supply Co., Oakland, Cal.
Const Electric Co., San Diego, Cal.
McGills, Melbourne, Australia
Radio Supply Co., Oakland, Cal.

50 cents from your dealer (75 cents in Canada) or direct from

Robert S. Kruse
Guilford, Conn.

(P.S. The 1st edition sold out in 90 days)

F. R. C. Warns on Secrecy Section of Radio Act

IN view of the ever-increasing sales of combination broadcast and short-wave radio receiving sets to the public, the Federal Radio Commission has issued a statement dated April 2, 1934, calling attention to provisions in the Radio Act of 1927, regarding the secrecy of certain radio messages and the heavy penalties provided for violations.

Section 27 of the Radio Act of 1927 provides:

Remember This!

"No person receiving or assisting in receiving any radio communication shall divulge or publish the contents, substance, purport, effect, or meaning thereof except through authorized channels of transmission or reception to any person other than the addressee, his agent, or attorney, or to a telephone, telegraph, cable, or radio station employed or authorized to forward such radio communication to its destination, or to proper accounting or distributing officers of the various communicating centers over which the radio communication may be passed, or to the master of a ship under whom he is serving, or in response to a subpoena issued by a court of competent jurisdiction, or on demand of other lawful authority; and no person not being authorized by the sender shall intercept any message and divulge or publish the contents, substance, purport, effect, or meaning of such intercepted message to any person; and no person not being entitled thereto shall receive or assist in receiving any radio communication and use the same or any information therein contained for his own benefit or for the benefit of another not entitled thereto; and no person having received such intercepted radio communication or having become acquainted with the contents, substance, purport, effect, or meaning of the same or any part thereof, knowing that such information was so obtained, shall divulge or publish the contents, substance, purport, effect or meaning of the same or any part thereof, or use the same or any information therein contained for his own benefit or for the benefit of another not entitled thereto: *Provided*, That this section shall not apply to the receiving, divulging, publishing, or utilizing the contents of any radio communication broadcasted or transmitted by amateurs or others for the use of the general public or relating to ships in distress."

Heavy penalties are provided in Section 33, of the same act, for violations of its provisions. That section reads:

"Any person, firm, company, or

THE NEW NORDEN

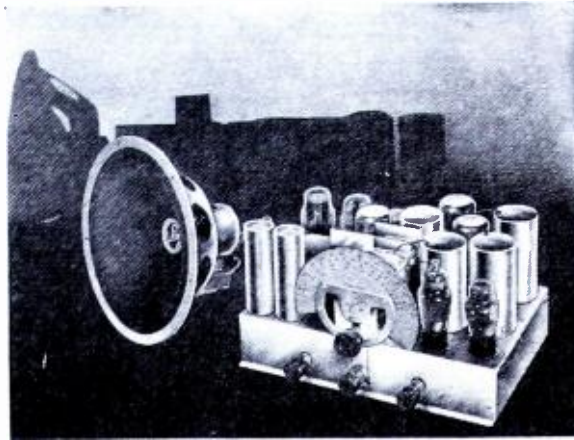

RADIO NOMAD

Superheterodyne

Proud bearer of a name distinguished in Radio, the Norden RADIO NOMAD is your "open sesame" to newer, finer all-wave reception. Never, within our knowledge, has so splendid a receiver been offered at such a startlingly low cost.

We have prepared a brochure describing the "NOMAD" in detail which will be sent upon request, together with new low prices.

NORDEN RADIO LABORATORIES

317 Fourth Avenue

New York City

AMAZING S. W. SET

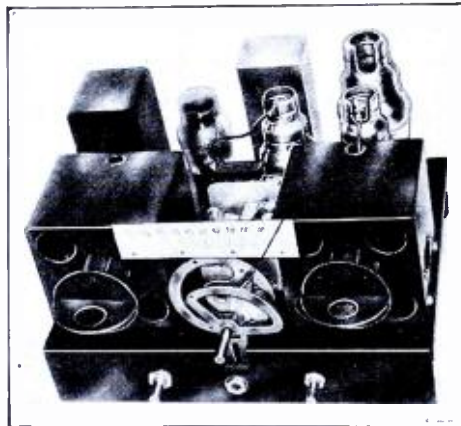

ALAN INTERNATIONAL

T.R.F. Circuit AC-DC Power Supply Front Panel Plug-in Coils

Available for 110 v. A. C.—D. C. S. W. 15—200 meters, also 220 v. A. C.—D. C., 2 and 6 v. battery operation, four tubes 2-78, 1-43, 1-2525. Completely shielded in black enameled, hinged cover, metal cabinet. Complete including 4 pairs of coils, 15-200m. \$24.95
Set Areturus tubes. 4.95
Complete Kit with Blueprints. 21.25

PRIZEWINNER

A. C.—D. C. S. W. (15 to 200 Meters)
Completely self powered, latest type 77-43 and 2525 Tubes. Provision for Head Phones and Speaker. Complete, less tubes, in rich enameled finish cabinet. Assembled, wired, tested, ready to plug in, including four coils. \$12.95
Kit of RCA or Areturus Tubes to match. 3.75
Complete Kit of parts, including 4 coils. 10.55

WRITE FOR FREE ALAN RADIO CORP. CATALOG & SHORT WAVE LIST 83 Corlandt St. Dept. 5WR New York City

DUBILIER CONDENSERS

1 mf—400 v.25
2 mf—400 v.30
6 mf—700 v.75
6 mf—900 v.95
.25 mf—1,000 v.30



Plugs and Jacks

Standoff Insulators

Servicemen's Condenser Kits \$3.45
(25 condensers from .1 to 2mf.)

A complete line of parts for the "ham" and experimenter.

Write for prices

KAY'S RADIO

179 Greenwich St., New York, N. Y.

"C'mup 'n See me Sometime"

If You Can't Come, Write

Don't be satisfied with ordinary reception. When you "tune in" you should know in advance there will be no interference of any kind. You are entitled to complete satisfaction and you can get it at small cost.



Whether you have a broadcast, short wave, automobile or all-wave receiver, you can get clearer, more realistic, noise-free radio reception by the use of the

LYNCH NOISE-FREE ANTENNA SYSTEM

It must outperform any other kind of aerial or so-called aerial eliminator, or it won't cost you a cent.

Write TODAY for Full Details

Satisfaction or Your Money Back

ARTHUR H. LYNCH, Inc. 51 Vesey St. New York, N.Y.

ALL ELECTRIC ALL-WAVE AIR SCOUT ONLY SET OF ITS KIND IN THE WORLD

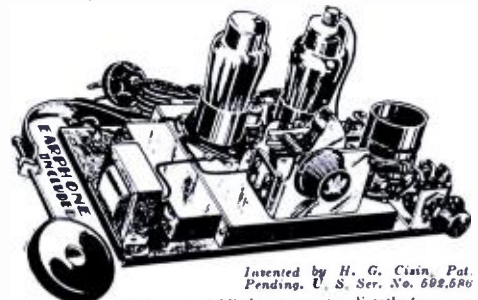

Invented by H. G. Cisin, Pat. Pending, U. S. Ser. No. 688,680

This powerful little set operates directly from any house lighting circuit, either a.c. or d.c. It brings stations, code and trans-Atlantic phone conversations. Uses five plug-in coils to cover band from 10 to 550 meters. Compact and light—makes an ideal portable. Will operate several headphones simultaneously and will work on a short indoor aerial.

Complete set, with two tubes, earphone, two coils covering band from 70 to 550 meters, ready to plug in and use. \$8.50

Same as above, less earphone. Postpaid \$8.00
Three extra plug-in coils to cover band from 10 to 70 meters—50c each.

SPECIAL OFFER: Valuable data on All-Wave Receivers sent upon receipt of 10c to cover handling costs. Free circulars also available.

ALLIED ENGINEERING INSTITUTE

Est. 1921
98 Park Place - Dept. 542A - New York, N. Y.
Phone BRclay 7-9540

Meet the "JIFFY 3"

As the name implies, the "JIFFY 3" is a short-wave kit that practically assembles itself. This remarkable receiver has a moulded Bakelite base—RESISTANCE COUPLED throughout. Merely connect a few wires—take a few turns with a screwdriver, and in a jiffy you will be pulling in foreign stations—police calls—aircraft signals.

Has two 30's and a 32. Battery operated—light weight—world-wide reception—low current drain.

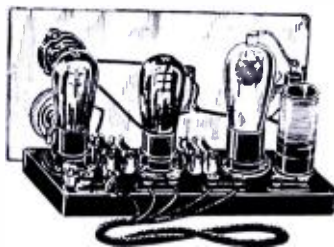

Complete KIT with set of 4 coils \$6.25
Wired - \$7.50 Tubes - \$1.50

LEOTONE RADIO CO., 65A Dey St., New York, N.Y.

Amateur Station LOG SHEETS

Paragraph 386 of the "Rules and Regulations Governing Amateur Radio Stations," issued by the Federal Radio Commission, reads as follows: "Each license of an amateur station shall keep an accurate log of station operation in which shall be recorded: (a) the date and time of each transmission; (b) the name of the person manipulating the transmitting key of a radio telegraph transmitter, or the name of the person operating a transmitter of any other type, with statement as to nature of transmission; (c) the station called; (d) the input power to the oscillator, or to the final amplifier stage, whether an oscillator-amplifier transmitter is employed; (e) the frequency band used; (f) the location of each transmission by a portable station.

"This information shall be made available upon request by authorized government representatives."

Be prepared! Lay in a supply of the new and simplified log sheets, as prepared by SHORT WAVE RADIO. These are the most sensible sheets brought out to date for ham use. Plenty of space to write in all the dope required by the F. R. C. Quick and easy to use, and can be filled-in in a hurry while you are "pounding brass." Also very useful for the short-wave broadcast listener.

These new log sheets measure full 8½ by 11 inches, are printed on high grade white paper that will take ink without smudging, are ready punched to fit any standard 3-ring note book binder, and are handier than bound books. You can make rough entries on one sheet, and then typewrite them on another for permanent record. This will make up a really swell log book that you will be proud to show. Nothing like these loose-leaf sheets for convenience.

Loose-leaf log sheets, package of 50, \$5.00

Postpaid anywhere in U. S. A. United States stamps, Post Office and Express Money Orders accepted. Do not send coins through the mail. These log sheets are carried in stock. Your order sent out same day it is received.

Standard Publications, Inc., 1123 Broadway, New York, N. Y.

"The Radio Amateur Call Book"

Over 50,000 calls listed in every issue. Always up-to-date. Contains high-frequency commercial stations, who's who on the short waves, special stations and expeditions, international call letters, and press, weather and time stations. Of great value to both the short-wave broadcast listener and the transmitting amateur. **THE ONLY CALL BOOK IN PRINT IN THIS COUNTRY!**

Single Copy **\$1.10** postpaid

Issued Quarterly—
March, June, September
and December

Annual Subscription **\$3.65** postpaid

Standard Publications, Inc., 1123 Broadway, New York, N. Y.

corporation who shall violate any provision of this act, or shall knowingly make any false oath or affirmation in any affidavit required or authorized by this act, or shall knowingly swear falsely to a material matter in any hearing authorized by this act, upon conviction thereof in any court of competent jurisdiction shall be punished by a fine of not more than \$5,000 or by imprisonment for a term of not more than five years or both for each and every such offense."

Violator Arrested

Reports reaching the Commission indicate that the public is increasingly intercepting police and other short-wave communications. Only in rare instances, it is believed, is this information abused. However, it was brought to the attention of the Commission that a young man in Baltimore intercepted a police call on a short-wave receiver in his home and notified law violators that officers were coming to arrest them. The young man himself was taken into custody and found guilty in a police court for violating police regulations.

Congress has given serious consideration to a bill providing that "no person shall use, operate or possess, in any vehicle within the United States, or any place subject to the jurisdiction thereof, any short-wave radio receiving set without a permit."

Provision is made for permits to be issued by District Attorneys, to applicants, who must furnish two affidavits executed by bonafide residents of their districts, vouching for the good moral character of the applicants.

Police officials in some cities are in favor of such legislation as they claim their work in apprehending criminals and in protecting law-abiding citizens, in some instances, has been interfered with by persons who intercepted messages intended solely for the police.

Legislation Not Desired

However, the Commission is hopeful that no such legislation will be necessary as it would have a tendency to hinder experimental work in the short-wave field.

George B. Porter, acting general counsel, says that if any serious abuse is made by the general public of private radio messages vigorous steps will be taken to invoke the law.

In order that the public may be fully informed concerning the protection thrown around private radio messages, the Commission suggests that each purchaser of a combination broadcast and short-wave receiver be furnished by the salesman with the excerpts of the Radio Act concerning the secrecy of radio

messages and the penalty for violations.

Editor's Note

It is refreshing to observe that the Federal Radio Commission is not in favor of legislation prohibiting short-wave radio in automobiles. Police officials who sponsor such legislation are altogether ignorant of radio and do not seem to realize that there is nothing as unsecret as a radio message transmitted by voice. Instead of taking the sensible and logical step of coding their broadcast alarms, they are attempting the futile and impossible job of keeping receiving sets out of cars. We realize that laws of this kind are not intended so much to prevent an unlawful act as to give the police a legal excuse to hold suspicious persons, but why must such foolish measures be taken when better methods are available?

Radio Messages Enciphered

It is a cardinal principle of military communication that all radio messages must be enciphered. Messages are sent "in the clear" only when the information they contain is of no immediate tactical advantage to the enemy, and they are accepted by message centers only over the signature of a responsible officer. The colossal stupidity of certain Russian officers in sending radio messages in clear text during the early stages of the World War enabled the Germans to anticipate some very important troop movements and to smash the Russian Army before it had hardly started operations. Many other similar cases were reported.

Are not police and criminals engaged in a war just as bitter as any battlefield conflict, and far more enduring? Why do the police broadcast their business to the whole world and then complain poutingly that their most important enemies are a step ahead of them, having intercepted the very messages aimed against them? They cry for more laws, instead of improving their ability to use the weapons already at their disposal.

New York "Code" Known

A few progressive police departments are already experimenting with partially coded alarms. New York has a system of numbered signals, but evidently no particular effort has been made to keep it confidential, and it has been described in detail in the daily press. A cipher is only as dependable as the personnel using it; in times of war people who steal or divulge codes learn what firing squads are for!

Other radio services have worked out their problems without hindering the normal progress of development work; why can't the police?
—Robert Hertzberg.

POSTAL BOOSTER



IMPROVES RECEPTION ON ANY SHORT OR ALL-WAVE SET

Something the short-wave fan has been waiting for, for a long, long time. The Postal Short Wave BOOSTER will increase the sensitivity and selectivity of your present receiver over 300%. It eliminates repeat spots, image frequencies and lowers

the background noise considerably. If you are interested in hearing foreign stations you could never hear before—If you have difficulty in separating the stations on the 49, 31, 19 and 16 meter bands—If you are troubled with stations repeating on different points of the dial—If your background noise is high—DO NOT hesitate—Purchase a Postal Pre-selector and BOOSTER.

1.25Z5 and uses the new drawer coils. An illuminated airplane dial is used for the main control. It is also equipped with a gain control and a switch to cut the BOOSTER in and out of the circuit. Mounted in a beautiful sturdy crystal finish cabinet with rubber legs. It measures 8 1/2 x 9 1/4 x 6".

SIMPLE TO OPERATE

The Postal BOOSTER can be connected to your set in less than a minute. No tools or soldering necessary. The Postal BOOSTER will improve any short or all-wave receiver, regardless of the make or the price paid. Operates from either 110 volts AC-DC or battery. Simple instructions furnished with each unit. Guaranteed for one year. Prompt deliveries.

PRICES

Sold complete, laboratory constructed, with one drawer coil for any band..... **\$19.95**

Matched set of tubes 2-78, 1-25Z5..... **1.95**

Drawer coils available for (14 to 20) (20 to 56) (56 to 90) and (90 to 200) meters..... **3.95**

When ordering please specify name of your receiver. Send for free circular describing the Postal International all wave set as used by Captain Horace L. Hall.

POSTAL RADIO 135-H Liberty Street New York, N. Y.

CONSTRUCTION
Each Postal BOOSTER is actually laboratory tested and calibrated. It employs 2-78 R.F. pentodes.

When Seeking a Radio School

Consider RCA Institutes . . . 25 years old . . . an institution recognized as an important factor in the radio industry.

The beginner who seeks instruction in any branch of radio will find courses designed for him . . . either at the Resident Schools in New York and Chicago or the RCA Institutes Home Study courses.

Resident Schools are fully equipped—conveniently located—low weekly tuition rates.

FEATURES OF RCA INSTITUTES HOME STUDY COURSES

Extension courses for home study on convenient "no obligation" plan. Examination and technical advisory services. Free post-graduate practical training at resident school with modern equipment under instructing engineers.



Write for Catalog

RCA Institutes, Inc.

Dept. SR-6
75 Varick Street, New York
1154 Merchandise Mart, Chicago

There is a handy subscription blank on page 48. Use it! \$2.50 per year in U. S. and possessions. \$3.00 per year in foreign countries.

SHORT WAVE RADIO

RCP · RCP · RCP · RCP · RCP · RCP

"DEPENDABLE"

All-Wave

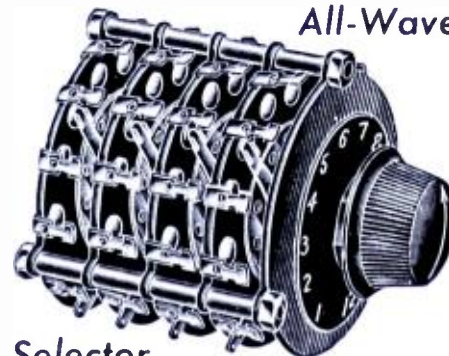

Selector

SWITCH

"DEPENDABLE" in name and dependable in fact, because *better built* and having distinctive refinements always associated with RADIO CITY PRODUCTS.

Smooth, positive, self cleaning, low-resistance contacts, special alloy. Shaft insulated from contact arm. Bakelite shaft supplied on order for ultra shortwave work. Bakelite insulation. Very low capacity.

Stock sizes: 1 to 7 gangs, with 3 to 12 contacts. List prices, 75c to \$4.55. Larger gangs to order. Furnished complete with dial plate and knob.

Write Dept. SWR 6 for complete data on switches and other Radio City Products.

RADIO CITY PRODUCTS CO.

Dept. SWR-6 48 West Broadway New York City

RCP · RCP · RCP · RCP · RCP · RCP

"M.J."

for the truly critical

Never before in the history of radio has so fine an All-Wave Receiver been offered the discriminating person to whom PERFORMANCE is more important than PRICE.

Employing twelve tubes, this fine superheterodyne embodies the latest engineering advances in radio. Comparative tests show it to easily out-perform receivers costing *many dollars more*.

Custom built to the most exacting standards, it provides the ultimate in 1934 reception.

Booklet 52, describing the "M.J." in detail, will be mailed upon request.

PIONEER SOUND LABORATORY

135 Liberty Street, New York, N. Y.

World-Wide Short Wave Receivers 15 to 200 Meters



MILES D_{x2} Uses 6E5, 6F7, 37 tubes as RF amp., regenerative detector, and audio amplifier, 110 V. AC filament operation, 1.5 V. B. batteries mounted on heavy black cradle finished with chrome and panel included. Kit, as enclosed. **\$7.85**

Wired and tested **8.85**

Tubes **1.75**



ALL-ELECTRIC 2 Uses 6E7, 6X4 tubes as screen grid regenerative detector, one stage audio amp., complete built-in power supply; mounted on heavy black cradle finished chassis and panel; coils included; for 110 V. AC DC kit, as assembled. **\$8.85**

Wired and tested **9.85**

Tubes **1.80**

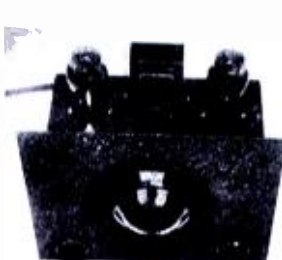

DC2 Dry battery operated; uses 30 30 tubes as regenerative detector, one stage audio amp.; mounted on heavy black cradle finished chassis and panel; sensitive and quiet in operation; coils included. **\$5.95**

Wired and tested **6.95**

Tubes **1.50**

POWER SUPPLY Uses 25Z5 tube; delivers plate voltage only; adjustable for 110 V. AC, kit, a cradle on black cradle finished chassis, **\$4.95**. Tube, **\$1.20**. Complete wiring diagrams and instructions furnished with all of the above kits.

EILEN RADIO LABORATORIES, 24 West 20th St., New York, N.Y.

Gould "Add-A-Stage"

THE COLOR CODED SET

15-550
Meters

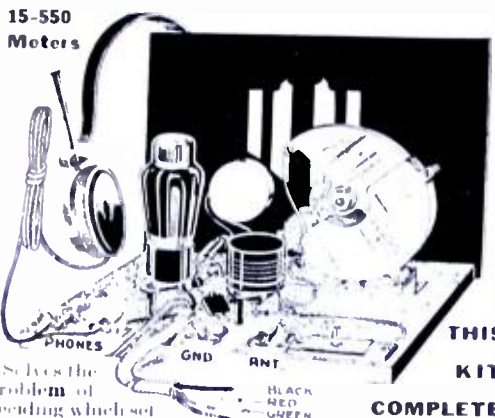

Solves the problem of deciding which set to build - start with a ONE TUBE adding one or two stages later, using same parts, baseboard, cable, etc. The three-tube set operates a loud speaker, either dynamic or magnetic.

Very sensitive gets **GSA** (England), **COC** (Cuba), **HBP** (Switzerland), **EAQ** (Spain), **PHI** (Holland), **ZRO** (Italy) - covers broadcast, police, transatlantic, etc.

EASY TO WIRE - seventeen different colored wires, a separate colored wire for each connection. Complete diagrams and instructions to construct any one of five different, approved S.W. circuits. No cutting, just screw driver and soldering iron.

ALL PARTS SUPPLIED - including black and silver finished panel, drilled baseboard, variable condenser, sockets, condensers, resistors, hardware, knobs, etc. Including headphones, dry cell tubes, and FOUR plug-in coils. In fact, everything but the batteries. Broadcast coil is fifty cents extra.

Complete parts and tube for extra kit stage **\$1.50**

EXTRA! Any type set wired ready to play **<1.00**

Complete parts and tube for extra Audio Stage, **\$1.50**

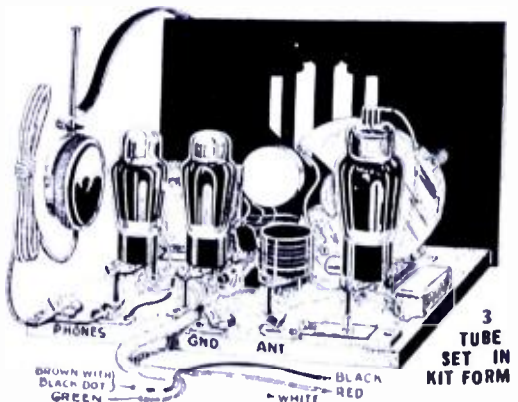

This situation shows the three-tube "ADD-A-STAGE" - built on the same chassis as the ONE TUBE, with the same parts. ALL PARTS SUPPLIED exactly the same as the ONE TUBE ABOVE and also includes three tubes (1-33, 2-34 pentodes, and audio transformer, four coils, R. F. stage headphone, etc., etc.)

Mail orders direct to

GOULD RADIO & TELEVISION CO.
172 SW Washington St., New York, N.Y.



SHORT WAVE COILS

Insulate an ICA quality when in need of S.W. coils because of their greater efficiency.

ICA BAKELITE RIBBED COILS
Wave lengths 16-217 meters, 4 prongs, No. 1429, List Price, **\$3.00**

Wave lengths 16-200 meters, 6 prongs, 3 windings, No. 1428, List Price, **\$3.75**

Also available in **ULTRA LOW WAVE** lengths from 9-21 meters, and broadcast bands 190-550 meters.

OTHER ICA COILS FOR ECONOMY
No. 1431, 16-217 meters, 4 prongs, Bakelite, List Price, **\$2.00**

No. 1432, 16-200 meters, 6 prongs, Bakelite, List Price, **\$3.00**

ICA INSULEX WITH HANDLE GRIP
No. 951, 4 prongs, 16-217 meter, List Price, **\$4.00**

No. 965, 6 prongs, 16-217 meter, List Price, **\$5.00**



Your jobber or favorite Mail Order House can supply you with any ICA product at 10% discount. If not write us direct.

STANDARD RACK PANELS

Supplied in 60 sizes. Our Special Order Department will machine or engrave panels to your specifications in Dural, Aluminum, Bakelite, Electrolux, Zinc, Hard Rubber, Steel, Brass, Asbestos. Lowest prices. Send blueprint for quotation or ask for Folder P 1.

WIRING DIAGRAMS FREE together with Big New SPECIALIZED S.W. CATALOG. All new and valuable S.W. Data. LIST PRICES on converters, coils, condensers, choke, etc.

INSULINE CORP. OF AMERICA

23-25 Park Place Dept. S-64 New York, N. Y.

Should the Ground Wire Be Insulated?

In regard to a statement made in our May issue to the effect that the ground wire need not be insulated, Mr. K. G. Schlicker, 106 E. Broad Street, Bethlehem, Pa., writes:

"I find it necessary and desirable to thoroughly insulate the ground wire all the way from the point with which it makes contact with the water pipe, etc., to the radio set.

"I have found that between ground pipe and radio set there is a large potential difference which causes trouble when a bare portion of the ground wire touches a grounded point intermediate between the ground and the radio set. One particular case of an AK superhet was solved by separating the BX cable in the cellar from the water pipe. This contact caused an ungodly noise in the radio set whenever any portion of the BX or wire vibrated. The BX was grounded to a water pipe.

"I should certainly not agree with your statement that it is unnecessary to insulate the ground wire from surrounding objects, and I think most active service men will agree with me."

Perhaps our original statement was a bit incomplete. We did not mean to infer that bare wire should be used or that insulation should be avoided. We didn't even have bare wire in mind, as all short-wave fans and service men we know of use ordinary single conductor No. 18 annunciator or rubber covered fixture wire for the ground connection. The insulation on this wire is quite adequate against the infinitesimal voltage developed between two separated ground connections.

What we meant in regard to "unnecessary" insulation were such things as porcelain knobs or cleats or fancy stand-off insulators. Since the covering of standard fixture wire safely withstands line voltages of 110 and over, it certainly is enough for the few millionths of a volt likely to appear in the aerial-ground circuit because of local earth currents.

SHORT WAVE EXCHANGE

Rates: 5 cents per word to amateurs, 8 cents to dealers and manufacturers. Minimum advertisement, 10 words. Cash with order.

THE ANSWER FACTORY has unsolved many puzzles of amateur and commercial operators. Prompt quotations, reasonable prices. Robert S. Kruse, RFD No. 2, Guilford, Connecticut.

QSL CARDS, Neat, Attractive, Reasonably priced. Samples Free. MILLER, SWR, Printer, Ambler, Pa.

FOR SALE: the original model of the 5-meter receiver described on page 38, November, 1933, issue of Short Wave Radio. Perfect condition. Completely wired, ready for operation. Less tubes and batteries, a bargain at \$5.00, postpaid. W21JU, 989 Tinton Avenue, Bronx, N. Y.

BATTERY short-wave receiver, three tubes, \$7.50. Four tube A.C. set, \$16.50 complete. W. A. Klesow, Morgan, Minn.

THE WORCESTER Constant Band Spread Superheterodyne receiver. Kits and completed receivers available. J. A. Worcester, Jr., 159 South Street, Middletown, N. Y.

SERVICEMEN: In order to acquaint you with the new 200-page book "ACTUAL TROUBLES IN COMMERCIAL RADIO RECEIVERS," we will send you absolutely free all necessary servicing data on any set you specify. There are no strings attached to this offer. Servicemen's Publishing Co., 136SR Liberty Street, New York, N. Y.

Can you solve these **SHORT-WAVE** problems?

1. Do you know what "dead spot." are and how to eliminate them?
2. Do you know how to "zero-beat" a station?
3. Do you know why certain frequencies are never good at certain times of the day?
4. Do you know all about "band spreading"?
5. Do you know all about "plug-in coil" design?
6. Do you know all about "waveband-switching" systems?
7. Do you know how to build "short-wave converters"?

GHIRARDI* *will send you the answers* **FREE!**

Simply clip and mail this coupon or send a postcard
(no obligation involved)

*A. A. Ghirardi is the author of the very popular **RADIO PHYSICS COURSE**, now in its second revised edition. The Course is a book of nearly a thousand pages, with over 500 diagrams and photographs, and an unusually complete index.

Short-wave fans say it is just the thing to give them the background they need for making further progress in short-wave radio. Those who own the course will find the answers to the interesting questions above—and to many others—contained in the course with full explanations. The present price of the **RADIO PHYSICS COURSE** is only \$3.85, plus 15c for postage.

To: RADIO & TECHNICAL PUBLISHING CO.
45 Astor Place, Dept. S-6, New York

Gentlemen:

PLEASE SEND ME THE ANSWERS to those 7 short-wave problems.
No obligation.

Name

Address

City State

Occupation

have
SHORT WAVE RADIO
sent directly
to your home

If your local newsdealer does not carry a large stock of national magazines, you will find it much more convenient — and a little cheaper, too — to have **SHORT WAVE RADIO** sent directly to your home or office. A year's subscription costs only \$2.50 (\$3.00 in Canada and foreign countries), and your copies will reach you without delay. Use the handy coupon below. Post office or express money orders, bank checks and U.S. stamps accepted. Do not send coins through the mail.

Twelve issues of **SHORT WAVE RADIO** will bring you information and enjoyment worth many times the slight price of the magazine. Among the contributors you will find the best-known men in the short-wave field: Denton, Kruse, Worcester, Lynch, Cisin, Hall, Brennan and Shortt.

STANDARD PUBLICATIONS, INC.
 1123 Broadway, New York, N. Y.

Enclosed is \$ Send me **SHORT WAVE RADIO** for one year starting with the issue.

Name

No. and Street

City

State

Please write clearly

1818 pages of information!

**“THE HANDBOOK
 OF
 CHEMISTRY and PHYSICS”**

20th year of publication

FOR twenty years the Handbook of Chemistry and Physics has been giving a unique service to those in need of accurate tables, formulas and scientific data in a single convenient volume. The Eighteenth Edition represents a 20-year accumulation of necessary data for the busy scientist, engineer and experimenter, that is not only acceptable but highly essential in the commercial, educational, research and home laboratory.

Constant revision, year by year, brings you, in this 20th Anniversary Edition, 1818 pages of the most up-to-date data procurable. With the Eighteenth Edition available, you do not need to rely upon obsolete reference works, incomplete data or original papers which are often hard to locate. Of particular interest to the radio experimenter are the greatly enlarged table of characteristics of Thermionic tubes, dozens of valuable tables of mathematical functions and formulas and numerous chapters on sound, electricity and light.

This handbook is generally regarded as the most complete single reference book for the scientific worker. It is the kind of book that you will keep on your desk or work-table, not in the bookcase.

Price **\$6⁰⁰** postpaid

(Special price to students; write for details)

order from

STANDARD PUB., INC.,
 1123 Broadway New York, N. Y.

ADVERTISERS' INDEX

Alan Radio Corporation	43
Allied Engineering Institute	43
Allied Radio Corporation	41
Blair the Radio Man, Inc.	38
Capitol Radio Engineering Institute	41
Eilen Radio Laboratories	46
Experimental Radio Laboratories	41
Fordson Radio, Inc.	42
General Electric Company	3
Gould Radio & Television Company	46
Hammarlund Mfg. Co.	3rd Cover
Insuline Corp. of America	46
Kay's Radio	43
Kruse, Robert S.	42
Leeds Radio	40
Leotone Radio Co.	44
Lynch, Arthur H., Inc.	43
McMurdo Silver, Inc.	41
National Co., Inc.	38
National Radio Institute	1
Norden Radio Laboratories	43
Pioneer Sound Laboratories	45
Postal Radio Corp.	45
Radio & Technical Pub. Co.	47
Radio City Products Co.	45
RCA Institutes, Inc.	45
Teleplex Company	42
Wholesale Merchandisers, Inc.	42
Wholesale Radio Service Co., Inc.	39

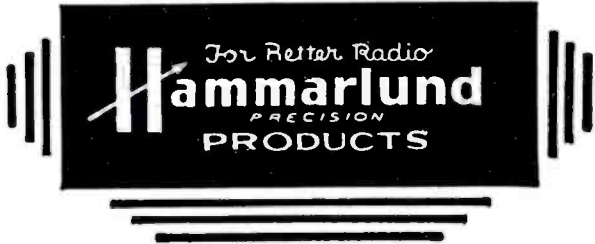
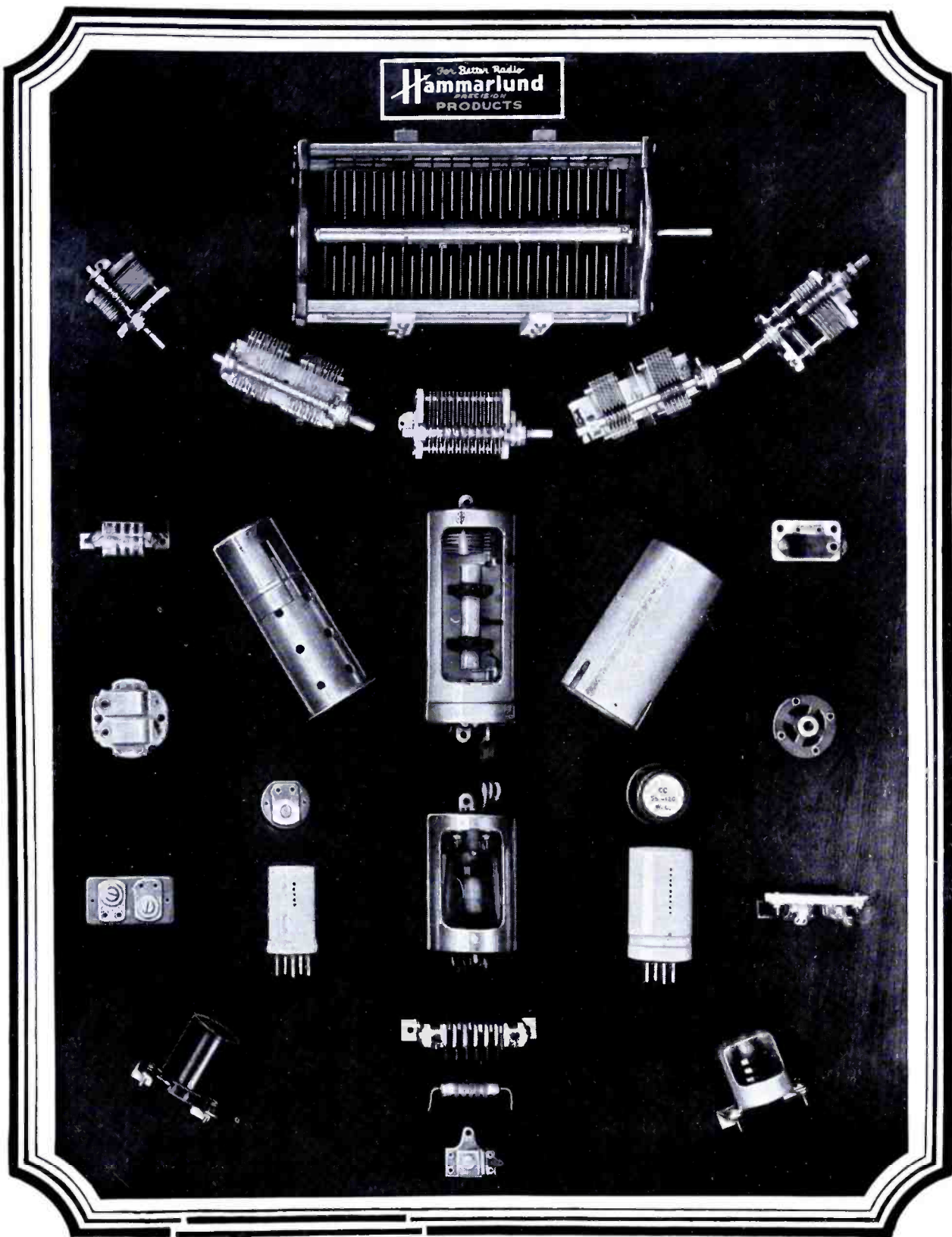

For valuable data on Short-Wave Reception and Transmission, write Dept. SR-6 for complete new catalog of Hammarlund Precision Products. A copy FREE for the asking.

HAMMARLUND MANUFACTURING CO.
 424-438 West 33rd Street, New York, N. Y.

And Now - -

We HAND it to -- YOU!

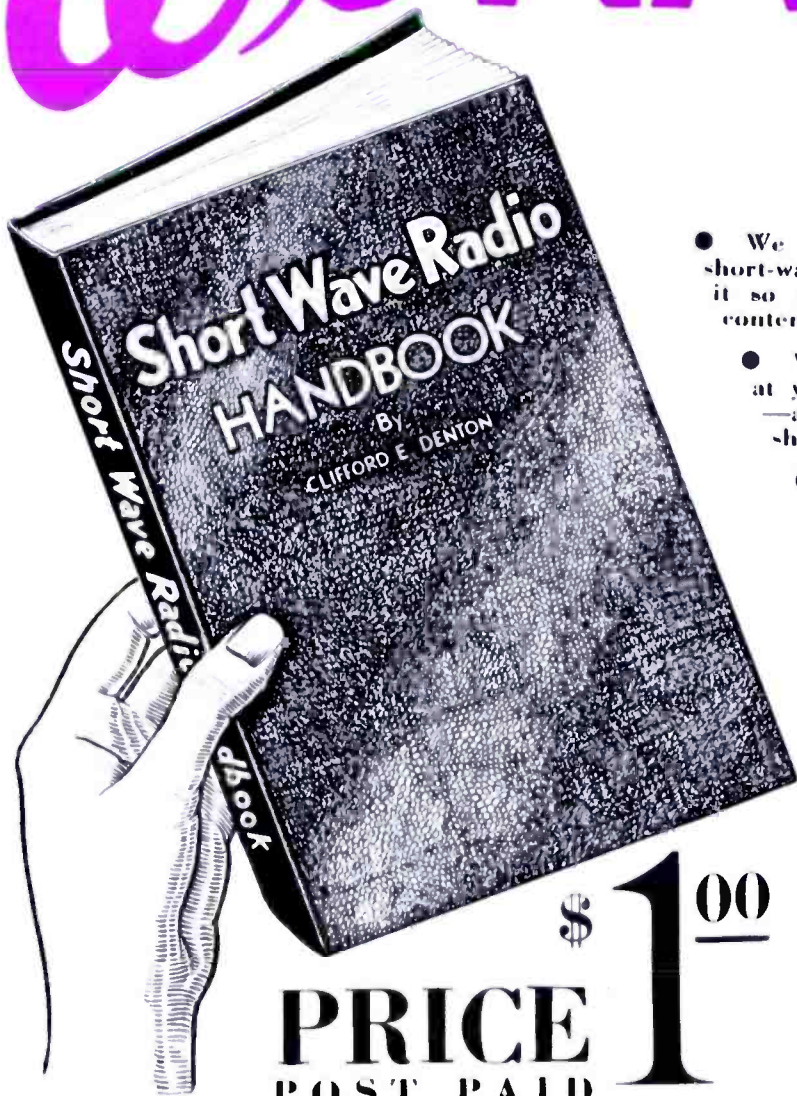

PRICE **\$1⁰⁰**
POST PAID

- We had to "hand it to Denton" at first for writing the greatest short-wave book in print; now, WE HAND IT TO YOU for accepting it so enthusiastically and for your appreciation of its excellent contents.
- We make no bones about this book. It was written for you at your request. It contains the type of information you want—and need. Coil data, circuits galore, construction material and short-wave tube information to the 128th page.
- We made it presentable, too. The paper is one of the finest grades obtainable. It will not turn yellow after a few months. The make-up is clean-cut, conservative, easy-to-read. There is no need to cover up this book when you glance over it in the train!
- We made the HANDBOOK so modern that it will not become obsolete for many years. It can't—it's so fundamentally sound and useful. It is, without doubt, the greatest dollar's worth the receiving amateur can obtain.

Order direct from your dealer or from us

List of National Distributors

AMERICAN NEWS CO. New York	GROSS RADIO New York
AMERICAN SALES CO. New York	HARVEY'S RADIO New York
BLAN THE RADIO MAN New York	LEEDS RADIO New York
BRENTANO'S Chicago	OFFENBACH ELEC. CO., Ltd San Francisco
BRENTANO'S New York	RADIO SUPPLY CO. Los Angeles
CENTRAL DE PUBLICACIONES S. A., Mexico City	SPOKANE RADIO CO. Spokane, Wash.
DIAMOND NEWS CO. Havana, Cuba	SUN RADIO CO. New York
EATON CO. T. New York	TREMONT ELEC. SUPPLY CO. Boston
FEDERATED PURCHASER, Inc., New York	WEDEL CO. Seattle, Wash.

Standard Publications, Inc.
1123 Broadway, New York, N. Y.

Gentlemen:
Enclosed please find \$1.00 (U. S. stamps, bank check, postal or express money order accepted) for which please send me one copy of Denton's SHORT WAVE RADIO HANDBOOK. (If a dollar bill is sent, wrap it up in several layers of paper.)

Name.....

Street and number.....

City and State.....

Please print clearly

READY FOR DELIVERY Your Copy Mailed Same Day Order Is Received

Standard Publications, Inc.
1123 Broadway
New York, N. Y.